

ANSI/UL1479 (ASTM E814)	CAN/ULC S115
F Rating - 2 Hr	F Rating - 2 Hr
T Rating - 0 and 1-1/2 Hr (See Item 3)	FT Rating - 0 and 1 Hr (See Item 3)
L Rating At Ambient - Less than 1 CFM / ft ²	FH Rating - 2 Hr
W Rating - Class 1 (See Item 3B)	FTH Rating - 0 and 1 Hr (See Item 3)
	L Rating At Ambient - Less than 5.1 L/s/m ²
	L Rating At 400 F — 15.3 L/s/m ²

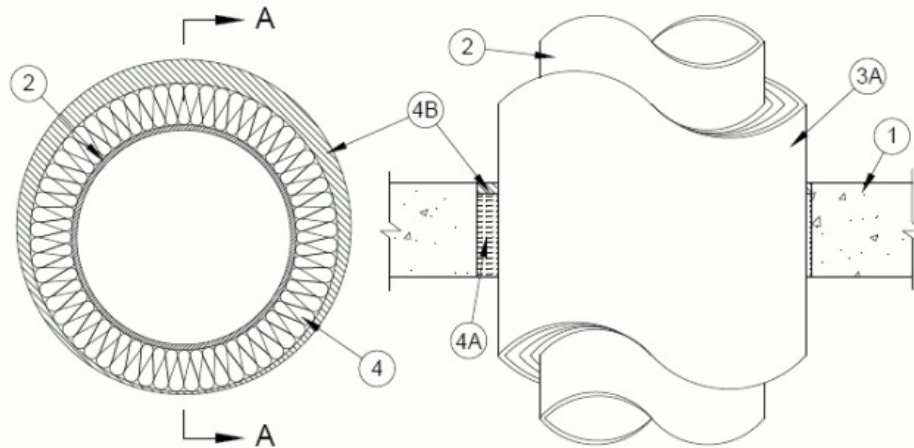

Section A-A

1. Floor or Wall Assembly — Min 4-1/2 in. thick reinforced lightweight or normal weight (100-150 pcf) concrete. Wall may also be constructed of any UL Classified **Concrete Blocks***. Max diam of opening is 16 in.

See **Concrete Blocks** (CAZT) in the Fire Resistance Directory for names of manufacturers.

2. Through-Penetrant — One metallic pipe, or tubing to be centered within the firestop system. Pipe, or tubing to be rigidly supported on both sides of floor or wall assembly. The following types and sizes of metallic pipes, or tubing may be used:

A. **Steel Pipe** — Nom 10 in. (254 mm) diam (or smaller) Schedule 10 (or heavier) steel pipe.

B. **Iron Pipe** — Nom 10 in. (254 mm) diam (or smaller) service weight (or heavier) cast iron soil pipe or Class 50 (or heavier) ductile iron pressure pipe.

C. **Copper Tubing** — Nom 3 in. (76 mm) diam (or smaller) Type M (or heavier) copper tubing.

D. **Copper Pipe** — Nom 3 in. (76 mm) diam (or smaller) Regular (or heavier) copper pipe.

3. Pipe Coverings — One of the following types of pipe coverings shall be used:

A. **Pipe and Equipment Covering and Materials*** — Nom 1-1/2 in. (38 mm) or thinner hollow cylindrical heavy density (min 3.5 pcf) glass fiber units jacketed on the outside with an all service jacket. Longitudinal joints sealed with metal fasteners or factory-applied self-sealing lap tape. Transverse joints secured with metal fasteners or with butt tape supplied with the product. A nom annular space of 5/8 in. (16 mm) is required within the firestop system. **The T Rating is 0 hr when pipe covering is less than 1-1/2 in. thick.**

See **Pipe and Equipment Covering — Materials** (BRGU) category in the Building Materials Directory for names of manufacturers. Any pipe covering material meeting the above specifications and bearing the UL Classification Marking with a Flame Spread Index of 25 or less and a Smoke Developed Index of 50 or less may be used.

B. **PVC Jacket** — (Optional, Not Shown) — An additional PVC jacket, supplied in sheet form, shall be tightly wrapped around the all service jacket on the pipe covering with the longitudinal seam continuously sealed using the adhesive supplied with the jacket. The jacket is to be nom 48 in. (1.22 m) wide by nom 20 or 30 mil (0.5 or 0.8 mm) thick. The jacket shall extend downward into and/or through the opening from a point 36 to 40 in. (0.91 to 1.02 m) above the top surface of the floor assembly. **The PVC jacket must be used for the W Rating to apply. The W Rating applies only with floor assemblies.**

See **Plastics** (QMFZ2) category in the Plastics Recognized Component Directory for names of manufacturers. Any Recognized Component plastic material meeting the above specifications and having a UL 94 Flammability Classification of 94-5VA may be used.

4. **Firestop System** — The firestop system shall consist of the following:

A. **Packing Material** — Min 3-1/2 in. (89 mm) thickness of min 4 pcf (64 kg/m³) mineral wool batt insulation firmly packed into opening as a permanent form. Packing material to be recessed from top surface of floor or from both surfaces of wall as required to accommodate the required thickness of fill material.

B. **Fill, Void or Cavity Material* - Caulk** — Min 1/2 in. (13 mm) thickness of fill material applied within the annulus, flush with top surface of floor or both surfaces of wall.

RECTORSEAL — FlameSafe® Silicone S/L (Self-Leveling) for floors only or FlameSafe® Silicone N/S (Non-Sag) for floors or walls, [Metacaulk 835+](#), Biotherm 100

*,+ Indicates such products shall bear the UL or cUL Certification Mark for jurisdictions employing the UL or cUL Certification (such as Canada), respectively.

Reprinted from the Online Certifications Directory with permission from UL. ©UL LLC