

F Rating — 2 Hr  
T Rating — 0 Hr

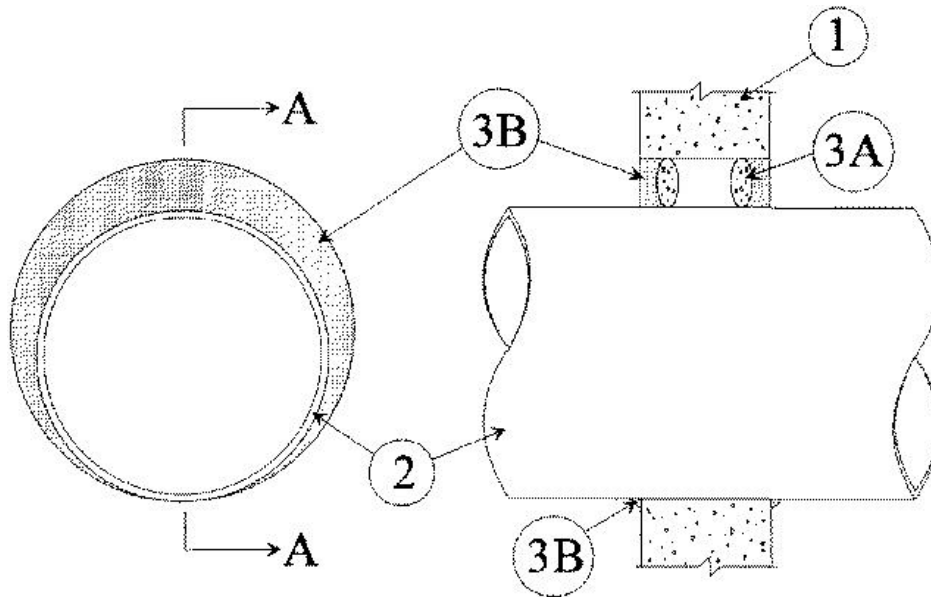

## SECTION A-A

1. **Wall Assembly** — Min 5 in. thick reinforced lightweight or normal weight (100-150 pcf) concrete. Wall may also be constructed of any UL Classified **Concrete Blocks**\*. Max diam of opening is 11-3/4 in. See **Concrete Blocks** (CAZT) category in the Fire Resistance Directory for names of manufacturers.

2. **Through Penetrants** — One metallic pipe, conduit or tubing to be installed either concentrically or eccentrically within the firestop system. Pipe, conduit or tubing to be rigidly supported on both sides of wall assembly. The following types and sizes of metallic pipes, conduits or tubing may be used:

A. **Steel Pipe** — Nom 10 in. diam (or smaller) Schedule 20 (or heavier) steel pipe. The annular space shall be min 0 in. to max 1 in.

B. **Iron Pipe** — Nom 10 in. diam (or smaller) cast or ductile iron pipe. The annular space shall be min 0 in. to max 1 in.

C. **Conduit** — Nom 4 in. diam (or smaller) steel electrical metallic tubing or steel conduit. The annular space shall be min 0 in. to max 1 in.

D. **Copper Tubing** — Nom 2 in. diam (or smaller) Type L (or heavier) copper tubing. The annular space shall be min 0 in. to max 1 in.

E. **Copper Pipe** — Nom 2 in. diam (or smaller) Regular (or heavier) copper pipe. The annular space shall be min 0 in. to max 1 in.

3. **Firestop System** — The firestop system shall consist of the following:

A. **Packing Material** — Foam backer rod firmly packed into opening as a permanent form. Packing material to be recessed from both surfaces of wall as required to accommodate the required thickness of fill material.

B. **Fill, Void or Cavity Material\*** — **Caulk** — Min 1/2 in. thickness of fill material applied within the annulus, flush with both surfaces of wall. At the point contact location between pipe and wall, a min 1/4 in. diam bead of fill material shall be applied at the wall/pipe interface on both surfaces of wall.

**RECTORSEAL** — [Metacaulk 1000](#)

\*,+ Indicates such products shall bear the UL or cUL Certification Mark for jurisdictions employing the UL or cUL Certification (such as Canada), respectively.