

ANSI/UL1479 (ASTM E814)	CAN/ULC S115
F Ratings - 1 and 2 Hr (See Item 1)	F Ratings - 1 and 2 Hr (See Item 1)
T Ratings - 1/2 and 1 Hr (See Item 2)	FT Ratings -1/2 and 1 Hr (See Item 2)
	FH Ratings -1 and 2 Hr (See Item 1)
	FTH Ratings -1/2 and 1 Hr (See Item 2)
L Rating At Ambient - Less Than 1 CFM/sq ft	L Rating At Ambient - Less Than 1 CFM/sq ft
L Rating At 400 F - Less Than 1 CFM/sq ft	L Rating At 400 F - Less Than 1 CFM/sq ft

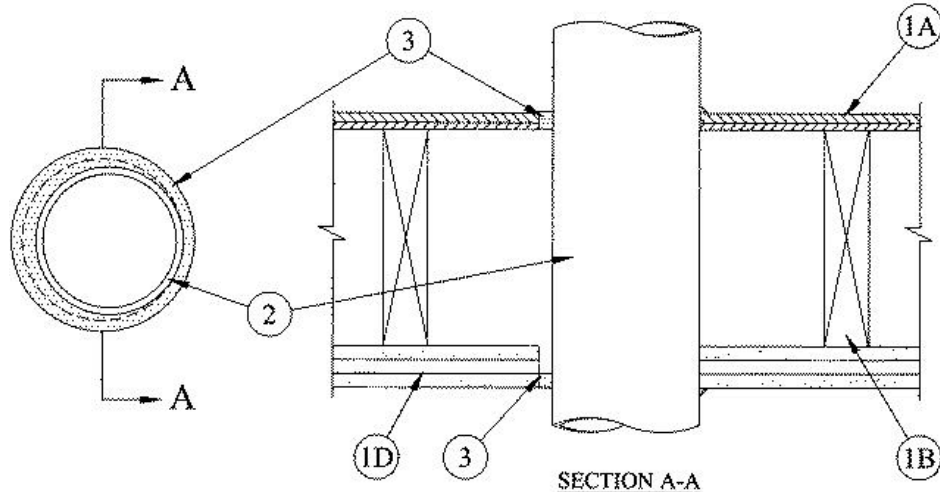

**1. Floor Ceiling Assembly** — The 1 hr fire-rated solid or trussed lumber joist floor-ceiling assembly shall be constructed of the materials and in the manner specified in the individual L500 Series Floor-Ceiling Designs in the UL Fire Resistance Directory. The 2 hr fire-rated wood joist floor-ceiling assembly shall be constructed of the materials and in the manner specified in Design Nos. L505, L511 or L536 in the UL Fire Resistance Directory. The general construction features of the floor-ceiling assembly are summarized below:

**A. Flooring System** — Lumber or plywood subfloor with finish floor of lumber, plywood or Floor Topping Mixture\* as specified in the individual Floor-Ceiling Design. Max diam of floor opening is 5 in. (127 mm).

**B. Wood Joists\*** — For 1 hr fire-rated floor-ceiling assemblies nom 10 in. (254 mm) deep (or deeper) lumber, steel or combination lumber and steel joists, trusses or **Structural Wood Members\*** with bridging as required and with ends firestopped. For 2 hr fire-rated floor-ceiling assemblies, nom 2 by 10 in. (51 by 254 mm) lumber joists spaced 16 in. (406 mm) OC with nom 1 by 3 in. (25 by 76 mm) lumber bridging and with ends firestopped.

**C. Furring Channels (Not Shown)** — (Not Shown) — In 2 hr fire-rated assemblies, resilient galv steel furring installed perpendicular to wood joists between first and second layers of wallboard (Item 1D). Furring channels spaced max 24 in. (610 mm) OC. In 1 hr fire-rated assemblies, resilient galv steel furring installed perpendicular to wood joists between wallboard and wood joists as specified in the individual Floor-Ceiling Design. Furring channels spaced max 24 in. (610 mm) OC.

**D. Gypsum Board\*** — Nom 4 ft (1.2 m) wide by 5/8 in. (16 mm) thick as specified in the individual Floor-Ceiling Design. First layer of gypsum board secured to wood joists or furring channels as specified in the individual Floor-Ceiling Design. Second layer of gypsum board (2 hr fire-rated assembly) screw-attached to furring channels as specified in the individual Floor-Ceiling Design. Max diam of ceiling opening is 5 in. (127 mm).

**The F Rating of the firestop system is equal to the hourly fire rating of the floor-ceiling assembly in which it is installed.**

**1.1 Chase Wall (Not Shown, Optional)** — The through penetrants (Item 2) may be routed through a 1 or 2 hr fire-rated single, double or staggered wood stud/gypsum board chase wall having a fire rating consistent with that of the floor-ceiling assembly. The chase wall shall be constructed of the materials and in the manner specified in the individual U300 Series Wall and Partition Designs in the UL Fire Resistance Directory and shall include the following construction features:

**A. Studs** — Nom 2 by 6 in. (51 by 152 mm) lumber or double nom 2 by 4 in. (51 by 102 mm) lumber studs.

**B. Sole Plate** — Nom 2 by 6 in. (51 by 152 mm) lumber or parallel 2 by 4 in. (51 by 102 mm) lumber plates, tightly butted.

C. **Top Plate** — The double top plate shall consist of two nom 2 by 4 in. (51 by 102 mm) lumber plates or two sets of nom 2 by 4 in. (51 by 102 mm) lumber plates tightly butted. Max diam of opening is 5 in. (127 mm).

D. **Gypsum Board\*** — Thickness, type, number or layers and fasteners shall be as specified in individual Wall and Partition Designs.

2. **Through Penetrants** — One metallic pipe, conduit or tubing to be installed either concentrically or eccentrically within the firestop system. The space between pipes, conduits or tubing and periphery of opening is dependent upon the type of penetrant within the firestop system. Pipe, conduit or tubing to be rigidly supported on both sides of floor or wall assembly. The following types and sizes of metallic pipes, conduits or tubing may be used:

A. **Steel Pipe** — Nom 4 in. (102 mm) diam (or smaller) Schedule 10 (or heavier) steel pipe. The annular space within the firestop system shall be a 0 in. (point contact) to max 1/2 in. (13 mm).

B. **Iron Pipe** — Nom 4 in. (102 mm) diam (or smaller) cast or ductile iron pipe. The annular space within the firestop system shall be a 0 in. (point contact) to max 1/2 in. (13 mm).

C. **Conduit** — Nom 4 in. diam (or smaller) steel electrical metallic tubing or rigid galv steel conduit. The annular space within the firestop system shall be a 0 in. (point contact) to max 1/2 in. (13 mm).

D. **Copper Tubing** — Nom 3 in. (76 mm) diam (or smaller) Type L (or heavier) copper tubing. The annular space within the firestop system shall be a 0 in. (point contact) to max 7/8 in. (22 mm).

E. **Copper Pipe** — Nom 3 in. (76 mm) diam (or smaller) Regular (or heavier) copper pipe. The annular space within the firestop system shall be a 0 in. (point contact) to max 7/8 in. (22 mm).

**The T Rating of the firestop system is dependent upon the type of penetrant, used within the firestop system. If a steel or iron pipe, steel electrical metallic tubing or rigid galv steel conduit is used, the T Rating is 1 hr. If a copper tube or copper pipe is used, the T Rating is 1/2 hr.**

3. **Fill, Void or Cavity Material\* — Sealant** — Min 3/4 in. (19 mm) thickness of fill material applied within the annulus, flush with the top surface of the floor or sole plate. Min 5/8 in. (16 mm) thickness of fill material applied within the annulus, flush with bottom surface of ceiling or bottom top plate. At point contact, min 3/8 in. (10 mm) diam bead of fill material applied at penetrant/floor or sole plate interface and at penetrant/ceiling or top plate interface. Additional sealant shall be applied in such a manner that the sealant overlaps a min 1/2 in. (13 mm) beyond the periphery of the opening on the top surface of the floor or sole plate and bottom surface of ceiling or bottom top plate.

**RECTORSEAL** — FS900+ Sealant, [Metacaulk MC 150+](#), Biostop [BF 150+](#)

\*,+ Indicates such products shall bear the UL or cUL Certification Mark for jurisdictions employing the UL or cUL Certification (such as Canada), respectively.

Reprinted from the Online Certifications Directory with permission from UL. ©UL LLC