

| ANSI/UL1479 (ASTM E814)                               | CAN/ULC S115                         |
|---|--------------------------------------|
| F Ratings — 1 and 2 Hr (See Item 1)                   | F Ratings — 1 and 2 Hr (See Item 1)  |
| T Rating — 0 Hr                                       | FT Rating — 0 Hr                     |
| L Rating At Ambient — Less Than 1 CFM/ft <sup>2</sup> | FH Ratings — 1 and 2 Hr (See Item 1) |
| L Rating At 400 F — Less Than 1 CFM/ft <sup>2</sup>   | FTH Rating — 0 Hr                    |

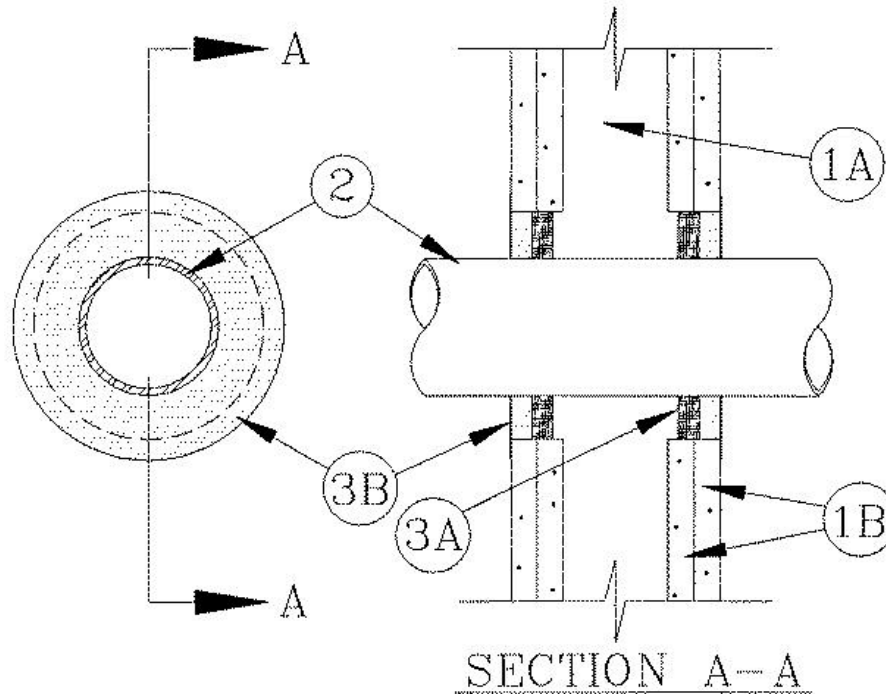

**1. Wall Assembly** — The 1 or 2 hr fire-rated gypsum board/stud wall assembly shall be constructed of the materials and in the manner specified in the individual U300, U400, V400 or W400 Series Wall and Partition Designs in the UL Fire Resistance Directory and shall include the following construction features:

**A. Studs** — Wall framing may consist of either wood studs or steel channel studs. Wood studs to consist of nom 2 by 4 in. (51 by 102 mm) lumber spaced 16 in. (406 mm) OC. Steel studs to be min 2-1/2 in. (64 mm) wide and spaced max 24 in. (610 mm) OC.

**B. Gypsum Board\*** — 5/8 in. (16 mm) thick, 4 ft (1.2 m) wide with square or tapered edges. The gypsum board type, thickness, number of layers, fastener type and sheet orientation shall be as specified in the individual Design in the UL Fire Resistance Directory. Max diam of opening is 5-1/2 in. (140 mm).

**2. Through-Penetrants** — One metallic pipe, conduit or tubing to be centered within the firestop system. A nom annular space of 1 in. (25 mm) is required within the firestop system. Pipe, conduit or tubing to be rigidly supported on both sides of wall assembly. The following types and sizes of metallic pipes, conduits or tubing may be used:

**A. Steel Pipe** — Nom 3 in. (76 mm) diam (or smaller) Schedule 5 (or heavier) steel pipe.

**B. Conduit** — Nom 3 in. (76 mm) diam (or smaller) steel electrical metallic tubing or steel conduit.

**3. Firestop System** — The firestop system shall consist of the following:

**A. Forms** — Optional, used as a form to prevent leakage of fill material during installation. Forms to be rigid sheet material, cut to fit the contour of the penetrating item and friction fitted into the opening on both sides of the wall. Forms to be recessed from both surfaces of the wall as required to accommodate the required thickness of fill material.

**B. Fill, Void or Cavity Material\* — Sealant** — For 2 hr fire-rated assemblies, min 1/2 in. (13 mm) thickness of fill material applied within the annulus, flush with both surfaces of wall. Additional fill material to lap 1 in. (25 mm) beyond the periphery of the opening.

For 1 hr fire-rated assemblies, min 1/2 in. (13 mm) thickness of fill material applied within the annulus, on both surfaces of wall. Additional fill material to be installed such that a min 5/8 in. (16 mm) crown is formed around the penetrating item and lapping 1 in. (25 mm) beyond the periphery of the opening.

---

**RECTORSEAL** — Types FS900, FS901, FS903, FS903G, FS905, FS905CG, FS929, FST901, FST903, FST905, [Metacaulk 150+](#)

\*,+ Indicates such products shall bear the UL or cUL Certification Mark for jurisdictions employing the UL or cUL Certification (such as Canada), respectively.

Reprinted from the Online Certifications Directory with permission from UL. ©UL LLC