

F Rating — 2 Hr
T Rating — 1-1/2 Hr

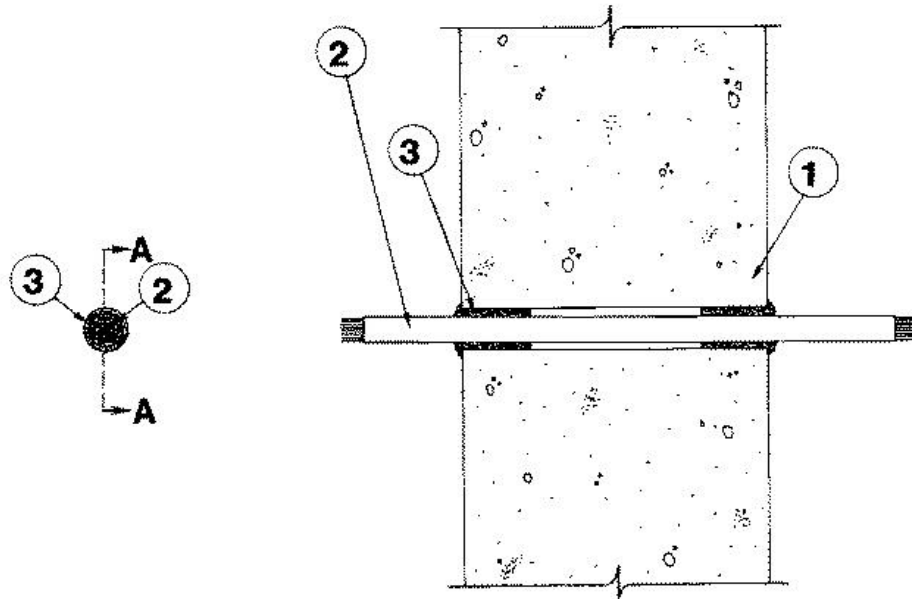

SECTION A-A

1. **Floor or Wall Assembly** — Min 4-1/2 in. thick reinforced lightweight or normal weight (100-150 pcf) concrete. Wall may also be constructed of any UL Classified **Concrete Blocks***. Max diam of opening is 1/2 in. See **Concrete Blocks** (CAZT) category in the Fire Resistance Directory for names of manufacturers.

2. **Cable** — Max 25 pair No. 24 AWG telephone cable, polyvinyl chloride insulation and jacket materials. One cable to be centered within the firestop system. A nom annular space of 1/8 in. is required within the firestop system. Cable to be rigidly supported on both sides of floor or wall assembly.

3. **Fill, Void or Cavity Material*** — **Caulk** — Caulk fill material to be forced within the annulus to max extent possible, flush with top surface of floor or with both surfaces of wall. Additional fill material to be installed such that a min 1/4 in. crown is formed around the penetrating item on both sides of wall and floor.

RECTORSEAL — [Metacaulk 950](#)

*,+ Indicates such products shall bear the UL or cUL Certification Mark for jurisdictions employing the UL or cUL Certification (such as Canada), respectively.

Reprinted from the Online Certifications Directory with permission from UL. ©UL LLC