

F Ratings — 1 and 2 Hr (See Item 1)  
 T Ratings — 0 and 3/4 Hr (See Item 1)

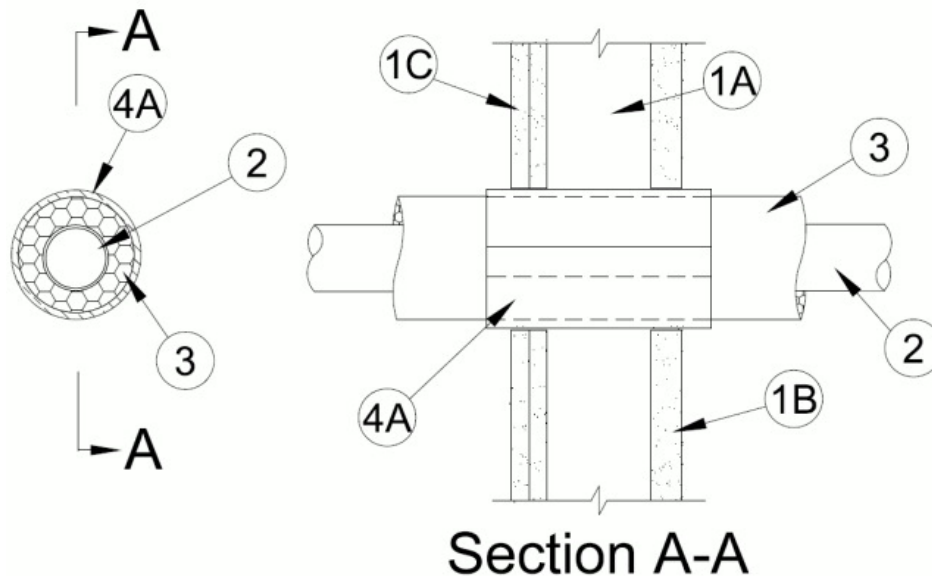

**1. Wall Assembly** — The 1 or 2 hr fire-rated gypsum board/stud shaft wall assembly shall be constructed of the materials and in the manner specified in the individual U400, V400 or W400 Series Wall and Partition Designs in the UL Fire Resistance Directory and shall incorporate the following construction features:

A. **Steel Studs** — "C-H" or "C-T" shaped studs, min 3-1/2 in. (89 mm) wide by 1-1/2 in. (38 mm) deep, fabricated from min No. 25 gauge galv steel, spaced max 24 in. (610 mm) OC.

B. **Gypsum Board\*** — 1 in. (25 mm) thick, 24 in. (610 mm) wide gypsum liner panels installed vertically. Diameter of the opening shall be 1/2 in. (13 mm) larger than OD of insulated penetrant. Max diam of opening is 6-1/2 in. (165 mm).

C. **Gypsum Board\*** — 5/8 in. (16 mm) thick, 48 in. (1.2 m) wide gypsum boards. The gypsum board type, thickness, number of layers, fastener type and sheet orientation shall be as specified in the individual Wall and Partition Design. Diameter of the opening shall be 1/2 in. (13 mm) larger than OD of insulated penetrant. Max diam of opening is 6-1/2 in. (165 mm).

**The hourly F Rating of the firestop system is equal to the hourly fire rating of the wall assembly in which it is installed. The hourly T Rating is 0 hr and 3/4 hr, for 1 and 2 hr rated assemblies, respectively.**

**2. Through Penetrants** — One tube installed concentrically within opening. Tube to be rigidly supported on both sides of wall assembly. The following types and sizes of metallic tubing may be used:

A. **Aluminum Tubing** — Reflok 6061-T4 ASTM B210 seamless aluminum tubing for use in closed (process or supply) piping systems. Tubing size shall be maximum 2-1/8 in. (54 mm) to minimum 1/4 in. (6 mm) outer diameter (OD) having wall thickness ranging from 0.080 in. (2 mm) to 0.030 in. (0.8 mm) respectively.

**3. Pipe Covering** — The following pipe covering shall be used with each Through Penetrant (Item 2).

A. **Tube Insulation-Plastics+** — Min 1/2 in. (13 mm) thick to max 1-1/2 in. (38 mm) thick Aerocel Ethylene Propylene Diene Terpolymer (EPDM) pipe insulation furnished in the form of tubing. The annular space between the insulated penetrant and the edge of the opening shall be 1/4 to 3/8 in. (6 to 9.5 mm).

See **Plastics+** - (QMFZ2) category in the Plastics Recognized Component Directory for names of manufacturers. Any Recognized Component tube insulation material meeting the above specifications of having a UL 94 Flammability Classification of 94-5VA may be used.

**4. Firestop System** — The firestop system shall consist of the following:

A. **Firestop Device** — Galv steel sleeve lined with an intumescent material and sized for the OD of the insulated penetrant. When outer diameter of insulated penetrant does not exceed 3-1/8 in. (79 mm), Intumescent Sleeve 234 shall be used. When OD of insulated penetrant exceeds 3-1/8 in. (79 mm), Intumescent Sleeve 68 shall be used. Device to be installed in accordance with the manufacturer's installation instructions along with the following. Device to be wrapped around outer circumference of insulated through penetrant and installed through the annular space of the opening, centered and friction fit within the wall and extending equally beyond each surface of the wall.

**RECTORSEAL** — [Metacaulk Intumescent Sleeve](#), Biostop Intumescent Sleeve or FlameSafe® Intumescent Sleeve



---

\*,+ Indicates such products shall bear the UL or cUL Certification Mark for jurisdictions employing the UL or cUL Certification (such as Canada), respectively.

Reprinted from the Online Certifications Directory with permission from UL. ©UL LLC