

ANSI/UL1479 (ASTM E814)	CAN/ULC S115
F Rating — 1 Hr	F Rating — 1 Hr
T Rating — 1 Hr	FT Rating — 1 Hr
L Rating At Ambient — Less Than 1 CFM/sq ft	FH Rating — 1 Hr
L Rating At 400 F — Less Than 1 CFM/sq ft	FTH Rating — 1 Hr
W Rating — Class 1 (See Item 2B)	L Rating At Ambient — Less Than 1 CFM/sq ft
	L Rating At 400 F — Less Than 1 CFM/sq ft

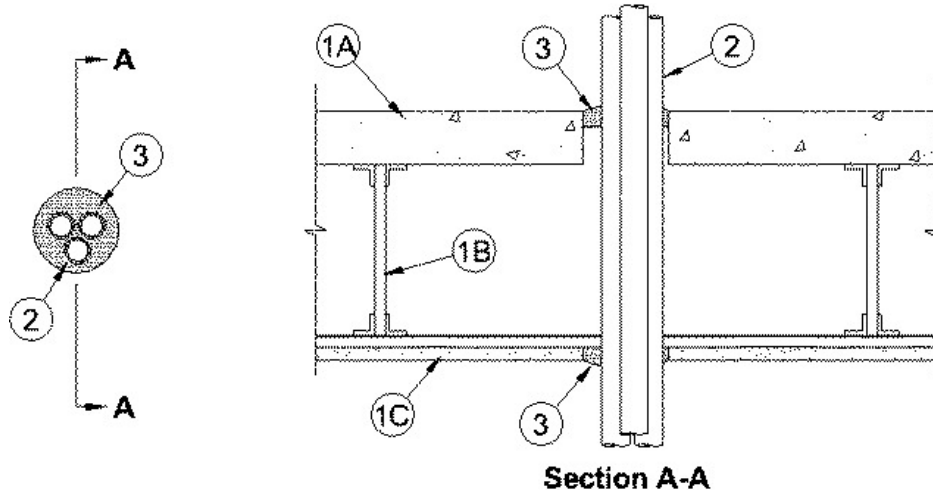

**1. Floor-Ceiling Assembly** — The 1 hr fire-rated concrete and steel joist Floor-Ceiling assembly shall be constructed of the materials and in the manner described in the individual G500 Series Design in the UL Fire Resistance Directory, as summarized below:

- A. **Concrete Floor** — Normal weight or lightweight (100-150 pcf or 1600-2400 kg/m<sup>3</sup>) concrete over metal lath or steel deck as specified in the individual G500 Series Design. Max diam of floor opening is 2 in. (51 mm).
- B. **Joists** — Steel joists or **Structural Steel Members\*** as specified in the individual G500 Series Design.
- C. **Gypsum Board\*** — Min 5/8 in. (16 mm) thick, screw-attached to furring channels as specified in the individual G500 Series Design. Max diam of ceiling is 2 in. (51 mm).

**2. Through Penetrant** — A max of three flexible steel conduits to be installed either concentrically or eccentrically within the firestop system. Of the three conduits, only one shall have a nom diam greater than 1/2 in. (13 mm). The annular space between the conduit shall be a min 0 in. (point contact) to a max 1/4 in. (6 mm). The annular space between the conduit and the periphery of the opening shall be a min 1/8 in. (3.2 mm) to a max 1/4 in. (6 mm). Conduits to be located approx midway between joists and rigidly supported on both sides of floor-ceiling assembly.

**3. Fill, Void or Cavity Materials\* — Sealant** — Min 3/4 in. (19 mm) thickness of fill material applied within the annulus, flush with top surface of floor. Min 5/8 in. (16 mm) thickness of fill material applied within the annulus, flush with bottom surface of ceiling. On both the top and bottom of the assembly, fill material forced into interstices within group of penetrating items to max extent possible. Additional fill material shall be installed such that a min 1/4 in. (6 mm) thick crown of fill material applied around the group of penetrants on both the top and bottom of the assembly.

**RECTORSEAL** — FlameSafe FS 1900, FS1901, FS1905, FS1929, [Metacaulk 1000](#), [Metacaulk 350i](#), Biostop 350i or Biostop 500+

\*,+ Indicates such products shall bear the UL or cUL Certification Mark for jurisdictions employing the UL or cUL Certification (such as Canada), respectively.

Reprinted from the Online Certifications Directory with permission from UL. ©UL LLC