

ANSI/UL1479 (ASTM E814)	CAN/ULC S115
F Rating — 2 Hr	F Rating — 2 Hr
T Rating — 2 Hr	FT Rating — 2 Hr
	FH Rating — 2 Hr
	FTH Rating — 2 Hr

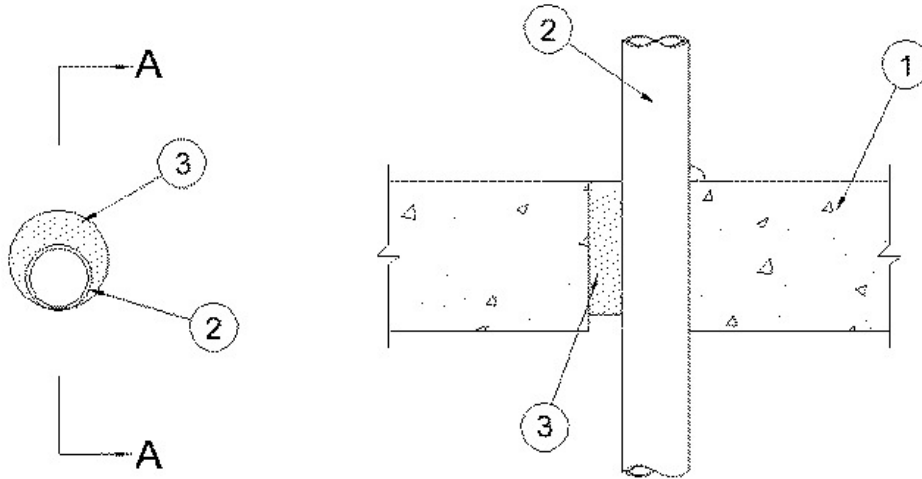

SECTION A-A

System tested with a pressure differential of 50 Pa between the exposed and the unexposed surfaces with the higher pressure on the exposed side.

1. **Floor or Wall Assembly** — Min 4-1/2 in. thick reinforced lightweight or normal weight (100-150 pcf) concrete. Wall may also be constructed of any UL Classified **Concrete Blocks***. Max diam of opening 3 in.

See **Concrete Blocks** (CAZT) category in Fire Resistance Directory for names of manufacturers.

2. **Polyvinyl Chloride (PVC) Pipe** — Nom 2 in. diam (or smaller) Schedule 40 solid core or cellular core PVC pipe for use in closed (process or supply) or vented (drain, waste or vent) piping systems. Annular space between pipe and periphery of the opening shall be min 0 in. (point contact) to max 5/8 in. Pipe to be rigidly supported on both sides of floor or wall.

3. **Fill, Void or Cavity Material* - Sealant** — Min 4 in. thickness of sealant applied within the annulus, flush with top surface of floor or both surfaces of wall. A min 1/2 in. diam bead of caulk shall be applied to the pipe/surface interface at the point contact location on the top surface of floor or both sides of wall.

RECTORSEAL — [Metacaulk 1000](#) or [Metacaulk 350i](#)

*,+ Indicates such products shall bear the UL or cUL Certification Mark for jurisdictions employing the UL or cUL Certification (such as Canada), respectively.

Reprinted from the Online Certifications Directory with permission from UL. ©UL LLC