

F Rating — 1 Hr
T Rating — 1 Hr

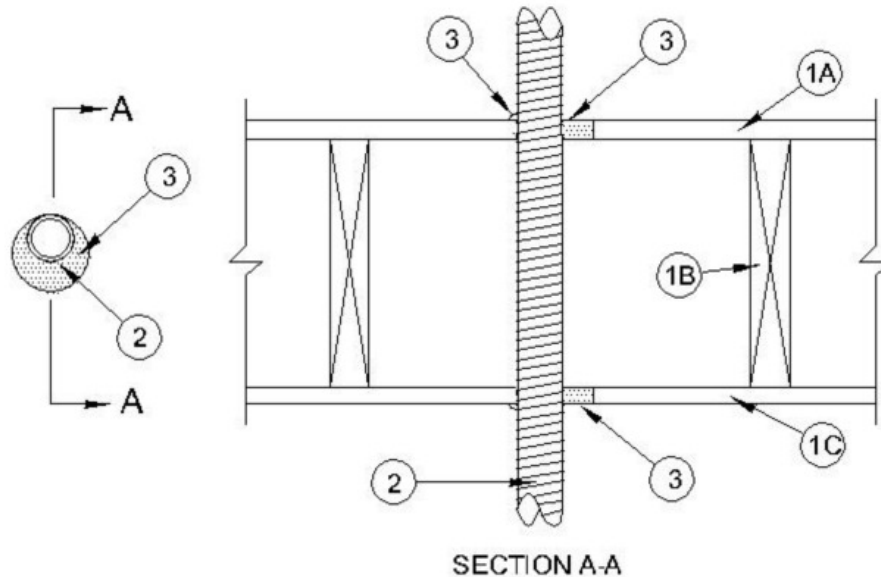

1. Floor - Ceiling Assembly — The 1 hr fire-rated wood joist floor-ceiling assembly shall be constructed of the materials and in the manner specified in the individual L500 Designs in the UL Fire Resistance Directory, as summarized below:

A. Flooring System — Lumber or plywood subfloor with finish floor of lumber, plywood or **Floor Topping Mixture*** as specified in the individual Floor-Ceiling Design. Max diam of floor opening is 3 in. (76 mm).

B. Wood Joists — Nom 10 in. (254 mm) deep (or deeper) lumber, steel or combination lumber and steel joists, trusses or **Structural Wood Members*** with bridging as required and with ends firestopped.

C. Gypsum Board* — Nom 5/8 in. (16 mm) thick as specified in the individual Floor-Ceiling Design. Gypsum board secured to joists as specified in the individual Floor-Ceiling Design. Max diam of ceiling opening is 3 in. (76 mm).

2. Through-Penetrant - Flexible Metal Piping — Nom 2 in. (51 mm) diam (or smaller) flexible metal piping to be installed eccentrically or concentrically within the firestop system. The annular space shall be min 0 in. (0 mm) to max 5/8 in. (6 mm). Piping to be rigidly supported on both sides of floor assembly.

3. Fill, Void or Cavity Material - Caulk — Min 3/4 in. (19 mm) thickness of fill material applied within annulus, flush with top surface of subfloor and min 5/8 in. (16 mm) thickness of fill material applied within annulus, flush with bottom surface of ceiling. At point contact locations, a min 1/4 in. (6 mm) diam bead of fill material shall be applied to the subfloor/piping and ceiling/piping interfaces

RECTORSEAL — [Metacaulk 1000](#)

*,+ Indicates such products shall bear the UL or cUL Certification Mark for jurisdictions employing the UL or cUL Certification (such as Canada), respectively.

Reprinted from the Online Certifications Directory with permission from UL. ©UL LLC