

F Rating — 3 Hr  
T Rating — 2-1/2 Hr  
W Rating - Class 1 (See Item 5)

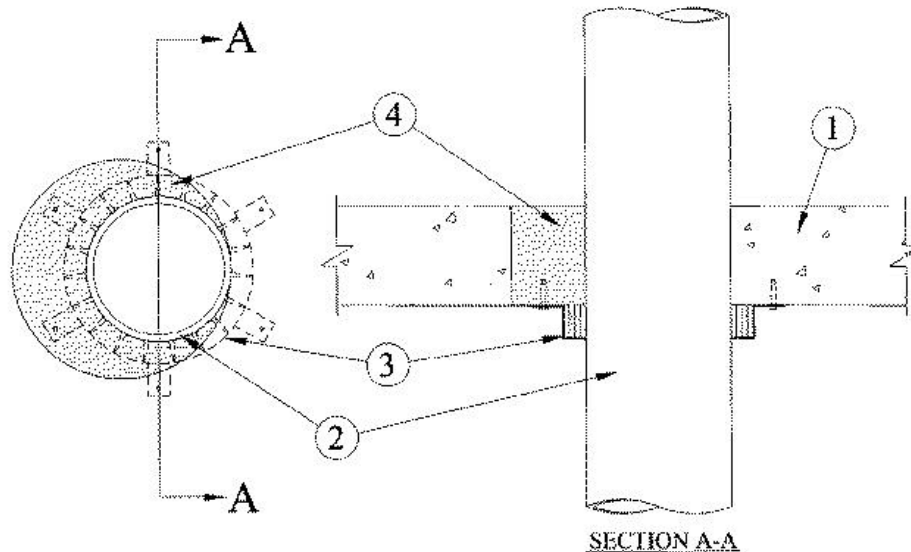

**1. Floor or Wall Assembly** — Min 4-1/2 in. thick reinforced lightweight or normal weight (100-150 pcf) concrete. Wall may also be constructed of any UL Classified **Concrete Blocks\***. Max diam of opening is 10 in.

See **Concrete Blocks** (CAZT) category in the Fire Resistance Directory for names of manufacturers.

**2. Through Penetrants** — One nonmetallic pipe to be installed either eccentrically or concentrically within the firestop system. The annular space shall be min 0 in. (point contact) to max 3-3/8 in. Pipe to be rigidly supported on both sides of floor or wall assembly. The following types and sizes of nonmetallic pipes may be used:

**A. Polyvinyl Chloride (PVC) Pipe** — Nom 6 in. diam (or smaller) Schedule 40 cellular or solid core PVC pipe for use in closed (process or supply) or vented (drain, waste or vent) piping systems.

**B. Chlorinated Polyvinyl Chloride (CPVC) Pipe** — Nom 6 in. diam (or smaller) SDR 17 CPVC pipe for use in closed (process or supply) piping systems. When pipe collars are provided on both sides of a wall, SDR 17 CPVC pipe may also be used in vented (drain, waste or vent) piping systems.

**C. Acrylonitrile Butadiene Styrene (ABS) Pipe** — Nom 6 in. diam (or smaller) Schedule 40 cellular or solid core ABS pipe for use in closed (process or supply) or vented (drain, waste or vent) piping systems.

**D. Flame Retardant Polypropylene (FRPP) Pipe** — Nom 6 in. diam (or smaller) Schedule 40 FRPP pipe for use in closed (process or supply) or vented (drain, waste or vent) piping systems.

**3. Firestop Device\*** — Galv steel collar lined with an intumescent material sized to fit specific diam of the through penetrant. Device to be installed around through penetrant in accordance with accompanying installation instructions. Device incorporates anchor tabs for securement to underside of the concrete floor by means of min 1/4 in. diam by 1-1/4 in. long steel expansion bolts or steel Tapcons® concrete anchors in conjunction with min 5/16 by 3/4 in. diam washers. Device secured at each tab. In walls, collars are installed on each side of wall.

**RECTORSEAL** — [Metacaulk Pipe Collar](#)

**4. Fill, Void or Cavity Materials\*** — **Mortar** — Min 4-1/2 in. thickness of fill material applied within the annulus, flush with the bottom surface of floor or with both surfaces of wall. Fill material is mixed at a rate of 2-1/2 parts dry mix to one part water by volume in accordance with the fill material manufacturer's installation instructions.

**RECTORSEAL** — [Metacaulk Fire Rated Mortar](#)

**5. Fill, Void or Cavity Materials\* - Caulk** — (Optional — Not Shown) Min 1/4 in. thickness of fill material applied within the annulus, flush with the bottom surface of floor or with both surfaces of wall.

---

**RECTORSEAL** — Metacaulk 1200

**W-Rating only applies when Metacaulk 1200 is used.**

\*,+ Indicates such products shall bear the UL or cUL Certification Mark for jurisdictions employing the UL or cUL Certification (such as Canada), respectively.

Reprinted from the Online Certifications Directory with permission from UL. ©UL LLC