

ANSI/UL1479 (ASTM E814)	CAN/ULC S115
F Ratings — 1 and 2 Hr (See Item 1)	F Ratings — 1 and 2 Hr (See Item 1)
T Ratings — 1 and 2 Hr (See Item 1)	FT Ratings — 1 and 2 Hr (See Item 1)
	FH Ratings — 1 and 2 Hr (See Item 1)
	FTH Ratings — 1 and 2 Hr (See Item 1)

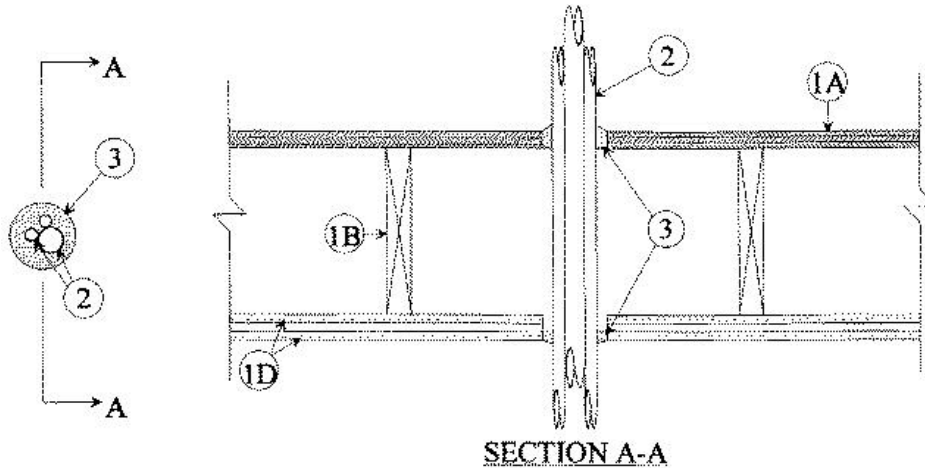

**1. Floor Ceiling Assembly** — The 1 hr fire-rated solid or trussed lumber joist floor-ceiling assembly shall be constructed of the materials and in the manner specified in the individual L500 Series Floor-Ceiling Designs in the UL Fire Resistance Directory. The 2 hr fire-rated wood joist floor-ceiling assembly shall be constructed of the materials and in the manner specified in Design No. L505, L511 or L536 in the UL Fire Resistance Directory. The general construction features of the floor-ceiling assembly are summarized below:

- A. Flooring System** — Lumber or plywood subfloor with finish floor of lumber, plywood or **Floor Topping Mixture\*** as specified in the individual Floor-Ceiling Design. Max diam of floor opening is 2 in. (51 mm).
  - B. Wood Joists** — For 1 hr fire-rated floor-ceiling assemblies nom 10 in. (254 mm) deep (or deeper) lumber, steel or combination lumber and steel joists, trusses or Structural Wood Members\* with bridging as required and with ends firestopped. For 2 hr fire-rated floor-ceiling assemblies, nom 2 by 10 in. (51 by 254 mm) lumber joists spaced 16 in. (406 mm) OC with nom 1 by 3 in. (25 by 76 mm) lumber bridging and with ends firestopped.
  - C. Furring Channels** — (Not Shown) — For 2 hr fire-rated assemblies resilient galv steel furring installed perpendicular to wood joists between first and second layers of gypsum board (Item 1D) and spaced max 24 in. (610 mm) OC. In 1 hr fire-rated assemblies, resilient galv steel furring installed perpendicular to wood joists between gypsum board and wood joists as specified in the individual Floor-Ceiling Design. Furring channels spaced max 24 in. (610 mm) OC.
  - D. Gypsum Board\*** — Nom 4 ft (1.2 m) wide by 5/8 in. (16 mm) thick as specified in the individual Floor-Ceiling Design. First layer of gypsum board nailed to wood joists. Second layer of gypsum board screw-attached to furring channels (2 hr fire-rated assembly). Max diam of ceiling opening is 2 in. (51 mm).
- The hourly ratings of the firestop system are equal to the hourly fire rating of the floor-ceiling assembly in which it is installed.**

**1.1. Chase Wall** — (Optional, not shown) — The through penetrant (Item 2) may be routed through a 1 or 2 hr fire-rated single, double or staggered wood stud/gypsum board chase wall having a fire rating consistent with that of the floor-ceiling assembly. The chase wall shall be constructed of the materials and in the manner specified in the individual U300 Series Wall and Partition Designs in the UL Fire Resistance Directory and shall include the following construction features:

- A. Studs** — Nom 2 by 6 in. (51 by 152 mm) or double nom 2 by 4 in. (51 by 102 mm) lumber studs.
- B. Sole Plate** — Nom 2 by 6 in. (51 by 152 mm) or parallel 2 by 4 in. (51 by 102 mm) lumber plates, tightly butted.
- C. Top Plate** — The double top plate shall consist of two nom 2 by 6 in. (51 by 152 mm) or two sets of parallel 2 by 4 in. (51 by 102 mm) lumber plates, tightly butted. Max diam of opening is 2 in. (51 mm).
- D. Gypsum Board\*** — Thickness, type, number of layers and fasteners shall be as specified in individual Wall and Partition Design.

**2. Through Penetrants** — A max of three flexible steel conduits to be installed either concentrically or eccentrically within the firestop system. Of the three conduits, only one conduit shall have a nom diam greater than 1/2 in. (13 mm). The space between the conduits shall be a min of 0 in. (point contact) to a max of 1/4 in. (6 mm). The annular space between the conduits and the periphery of the opening shall be a min 1/8 in. (3.2 mm) to a max 1/4 in. (6 mm). Conduits to be rigidly supported on both sides of floor-ceiling assembly.

**3. Fill, Void or Cavity Material\* — Caulk or Sealant** — Min 3/4 in. (19 mm) thickness of fill material applied within annulus on top surface of floor. Min 5/8 in. (16 mm) thickness of fill material applied within annulus on bottom surface of ceiling or lower top plate of chase wall assembly. Additional fill material to be installed such that a min 1/4 in. (6 mm) crown is formed around the through penetrants on top surface of floor and bottom surface of ceiling or lower top plate of chase wall assembly. Fill material to be forced into interstices of conduit bundle to max extent possible.

**RECTORSEAL** — FlameSafe FS1900, FS1901, FS1905, FS1929, [Metacaulk 1000](#), [Metacaulk 350i](#), Biostop 350i or Biostop 500+

\*,+ Indicates such products shall bear the UL or cUL Certification Mark for jurisdictions employing the UL or cUL Certification (such as Canada), respectively.

Reprinted from the Online Certifications Directory with permission from UL. ©UL LLC