

Assembly Ratings — 1, 2 and 3 Hr (See Items 1, 1A and 2)
Nominal Joint Width — 1 in.
Class II Movement Capabilities — 19% Compression or Extension
L Rating At Ambient - Less Than 1 CFM/Lin Ft
L Rating At 400 F - Less Than 1 CFM/Lin Ft

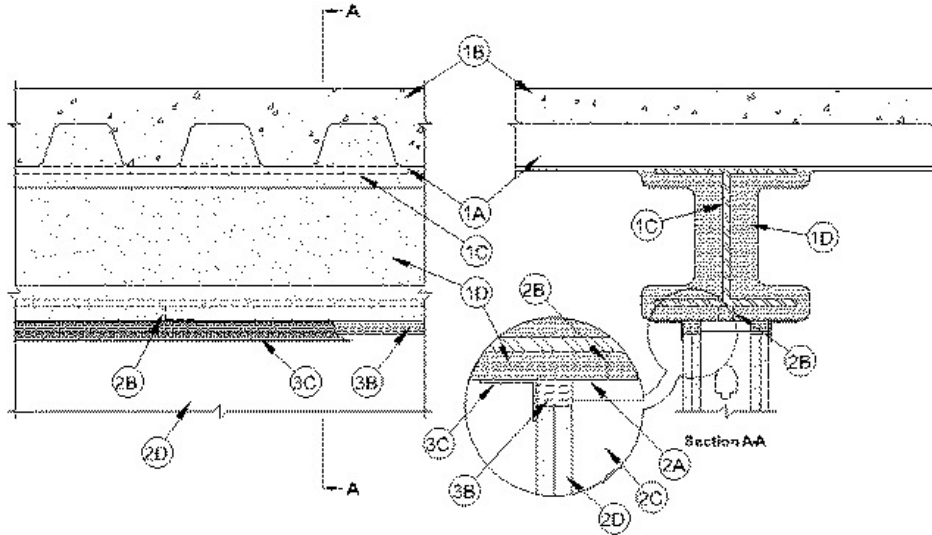

1. Floor Assembly — The fire-rated fluted steel deck/concrete floor assembly shall be constructed of the materials and in the manner described in the individual D700 or D900 Series Floor-Ceiling Design in the UL Fire Resistance Directory and shall include the following construction features:

A. Steel Floor And Floor Units* — Max 3 in. (76 mm) deep galv steel fluted floor units.

B. Concrete — Min 2-1/2 in. (64 mm) thick reinforced concrete, as measured from the top plane of the floor units.

C. Structural Steel Support — Steel beam, as specified in the individual D700 or D900 Series Floor-Ceiling Design, used to support steel floor units. Steel beam centered over and parallel with wall assembly.

D. Spray-Applied Fire Resistive Material* — After installation of the steel attachment clips (Item 2B), steel floor units and structural steel support to be sprayed with the min thickness of material specified in the individual D700 or D900 Series Design. The flutes of the steel floor units are to be filled with material across the entire top flange of the steel beam.

Additional material shall be applied to the web of the steel beam on each side of the wall. The min total thickness of material applied to each side of the steel beam web shall be 13/16 in. (21 mm) for 1 hr fire rated assemblies, 1-3/8 in. (35 mm) for 2 hr fire rated assemblies and 1-9/16 in. (40 mm) for 3 hr fire rated assemblies. For D700 Series Designs, all surfaces of the steel floor units to be sprayed with the thickness of material specified in the individual D700 Series Design. For D900 Series Designs structural steel supports only to be sprayed in accordance with the specifications in the individual D900 Series Design.

GCP APPLIED TECHNOLOGIES INC — Type MK-6/HY, MK-6/HYES, MK-65 and RG.

D1. Spray-Applied Fire Resistive Material* — After installation of the steel attachment clips (Item 2B), steel floor units and structural steel support to be sprayed with the min thickness of material specified in the individual D700 or D900 Series Design. The flutes of the steel floor units are to be filled with material across the entire top flange of the steel beam.

Additional material shall be applied to the web of the steel beam on each side of the wall. The min total thickness of material applied to each side of the steel beam web shall be 11/16 in. (18 mm) for 1 hr fire rated assemblies, 1-1/2 in. (38 mm) for 2 hr fire rated assemblies and 3 in. (76 mm) for 3 hr fire rated assemblies. For D700 Series Designs, all surfaces of the steel floor units to be sprayed with the thickness of material specified in the individual D700 Series Design. For D900 Series Designs structural steel supports only to be sprayed in accordance with the specifications in the individual D900 Series Design.

ISOLATEK INTERNATIONAL — Type 300

The hourly fire rating of the floor assembly shall be equal to or greater than the hourly fire rating of the wall assembly.

1A. **Roof Assembly — (Not Shown)** — As an alternate to the floor assembly, a fire-rated fluted steel deck roof assembly may be used. The roof assembly shall be constructed of the materials and in the manner described in the individual P900 or P700 Series Roof-Ceiling Design in the UL Fire Resistance Directory. The roof assembly shall include the following construction features:

A. **Steel Roof Deck** — Max 3 in. (76 mm) deep galv steel fluted roof deck.

B. **Roof Insulation** — For P900 Series Designs, min 2-1/4 in. (57 mm) thick poured insulating concrete, as measured from the top plane of the roof deck. For P700 Series Designs, roof insulation shall be as specified in the individual design.

C. **Structural Steel Support** — Steel beam, as specified in the individual P700 or P900 Series Floor-Ceiling Design, used to support steel floor units. Steel beam centered over and parallel with wall assembly.

D. **Spray-Applied Fire Resistive Material*** — (Not Shown) Prior to the installation of the joint system (Item 3) all surfaces of the roof deck to be sprayed with the thickness of material specified in the individual P700 Series Design. For D900 Series Designs structural steel supports only to be sprayed in accordance with the specifications in the individual P900 Series Design. The flutes of the steel roof deck are to be filled with material across the entire top flange of the steel beam.

Additional material shall be applied to the web of the steel beam on each side of the wall. The min total thickness of material applied to each side of the steel beam web shall be 13/16 in. (21 mm) for 1 hr fire rated assemblies, 1-3/8 in. (35 mm) for 2 hr fire rated assemblies and 1-9/16 in. (40 mm) for 3 hr fire rated assemblies.

GCP APPLIED TECHNOLOGIES INC — Type MK-6/HY, MK-6/HY ES, RG and MK-6S

D1. **Spray-Applied Fire Resistive Material*** — (Not Shown) Prior to the installation of the joint system (Item 3) all surfaces of the roof deck to be sprayed with the thickness of material specified in the individual P700 Series Design. For D900 Series Designs structural steel supports only to be sprayed in accordance with the specifications in the individual P900 Series Design. The flutes of the steel roof deck are to be filled with material across the entire top flange of the steel beam.

Additional material shall be applied to the web of the steel beam on each side of the wall. The min total thickness of material applied to each side of the steel beam web shall be 11/16 in. (18 mm) for 1 hr fire rated assemblies, 1-1/2 in. (38 mm) for 2 hr fire rated assemblies and 3 in. (76 mm) for 3 hr fire rated assemblies.

ISOLATEK INTERNATIONAL — Type 300

The hourly fire rating of the roof assembly shall be equal or greater than the hourly fire rating of the wall assembly.

2. **Wall Assembly** — The 1, 2 or 3 hr fire-rated gypsum board/stud wall assembly shall be constructed of the materials and in the manner described in the individual U400 or V400 Series Wall or Partition Design in the UL Fire Resistance Directory and shall include the following construction features:

A. **Steel Floor and Ceiling Runners** — Floor and ceiling runners of wall assembly shall consist of galv steel channels sized to accommodate steel studs (Item 2C). Ceiling runner to be provided with min 2 in. (51 mm) flanges. When deflection channel (Item 3A) is used, flange height of ceiling runner is to be equal to or greater than flange height of deflection channel and the ceiling runner is to nest within the deflection channel with a 1/2 in. to 3/4 in. (13 to 19 mm) gap maintained between the top of the ceiling runner and the top of the deflection channel. When deflection channel is not used, ceiling runner is secured to steel beam (Item 1A) with steel attachment clips (Item 2B) spaced max 24 in. (610 mm) OC. Ceiling runner or deflection channel to be centered beneath and parallel with bottom flange of steel beam. A clearance equal to the required thickness of spray-applied fireproofing material (Item 1D) shall be maintained between the top of the ceiling runner or deflection channel and the bottom flange of the steel beam.

A1. **Light Gauge Framing* - Slotted Ceiling Runner** — As an alternate to the ceiling runner in Item 2A, slotted ceiling runner consisting of galv steel channel with slotted flanges sized to accommodate steel studs (Item 2C) may be used. Slotted ceiling runner secured to steel beam (Item 1A) with steel attachment clips (Item 2B) spaced max 16 in. (406 mm) OC. Ceiling runner or deflection channel to be centered beneath and parallel with bottom flange of steel beam. A clearance equal to the required thickness of spray-applied fireproofing material (Item 1D) shall be maintained between the top of the slotted ceiling runner and the bottom flange of the steel beam.

METAL-LITE INC — The System

B. **Steel Attachment Clips** — Z-shaped clips formed from 1 in. (25 mm) wide strips of min 20 ga galv steel. Clips to be sized to extend through the thickness of the spray-applied fire-resistive material on the bottom flange of the steel beam with 2 in. (51 mm) long upper and lower legs. Legs of clips fastened to bottom of beam (prior to application of spray-applied fire-resistive materials) and top of ceiling runner (or deflection channel) with steel fasteners or welds. Clips spaced max 16 in. (406 mm) OC.

C. **Studs** — Steel studs to be min 3-1/2 in. (89 mm) wide. Studs cut 1/2 in. to 3/4 in. (13 to 19 mm) less in length than assembly height with bottom nesting in and secured to floor runner. When deflection channel (Item 3A) is used, steel studs

attached to ceiling runner (Item 2A) with sheet metal screws located 1/2 in. (13 mm) below the bottom of the deflection channel. When slotted ceiling runner (Item 2A1) is used, steel studs secured to slotted ceiling runner with No. 8 by 1/2 in. (13 mm) long wafer head steel screws at midheight of slot on each side of wall. When deflection channel or slotted ceiling runner is not used, studs to nest in ceiling runner without attachment.

D. Gypsum Board* — Gypsum board sheets installed to a min total 5/8 in., 1-1/4 in. and 1-1/2 in. (16, 32 and 38 mm) thickness on each side of wall for 1, 2 and 3 hr fire rated assemblies, respectively. Wall to be constructed in accordance with the individual U400 or V400 Series Design in the UL Fire Resistance Directory, except that a max 1 in. (25 mm) high gap shall be maintained between the top of the gypsum board and the bottom plane of the spray applied fire resistive material on the structural steel support member. The screws attaching the gypsum board to the studs along the top of the wall shall be located 1 in. (25 mm) below the bottom of the ceiling runner. No gypsum board attachment screws shall be driven into the ceiling runner or into the optional deflection channel.

The hourly fire rating of the joint system is equal to the hourly rating of the wall.

3. Joint System — Max separation between spray applied fire resistive material on bottom of structural support member and top of gypsum board (at time of installation of joint system) is 1 in. (25 mm). The joint system is designed to accommodate a max 19 percent compression or extension from its installed width as measured between bottom plane of the protective material on the steel beam and the top of the gypsum board. The joint system shall consist of forming and fill materials, with or without a deflection channel (Item 3A), as follows:

A. Deflection Channel — (Optional, Not Shown) - Max 2 in. (51 mm) deep min 24 gauge galv steel channel sized to accommodate ceiling runner (Item 2A). Deflection channel installed parallel with and centered beneath bottom flange of steel beam (Item 1C) and secured to steel beam with steel clips (Item 2B) spaced max 16 in. (406 mm) OC. The ceiling runner (Item 2A) is installed within the deflection channel to maintain a 1/2 in. to 3/4 in. (13 to 19 mm) gap between the top of the ceiling runner and the top of the deflection channel. A clearance equal to the required thickness of spray-applied fireproofing material (Item 1D) shall be maintained between the top of the ceiling runner or deflection channel and the bottom flange of the steel beam. The ceiling runner nests inside the deflection channel without attachment.

B. Forming Material* — Sections of nom 4 pcf (64 kg/m³) mineral wool batt insulation to be compressed 50 percent in thickness and installed cut edge first to completely fill the gap above the top of the gypsum board. The forming material shall be installed flush with both surfaces of wall.

INDUSTRIAL INSULATION GROUP L L C — MinWool-1200 Safing

JOHNS MANVILLE — Safing

ROCK WOOL MANUFACTURING CO — Delta Safing Board

ROCKWOOL MALAYSIA SDN BHD — SAFE

ROCKWOOL — SAFE

THERMAFIBER INC — SAF

C. Fill, Void or Cavity Material* - Sealant — Min 1/8 in. (3.2 mm) wet thickness or 1/16 in. (1.6 mm) dry thickness of fill material spray applied over the forming material on each side of the wall. Fill material to overlap min 1/2 in. (13 mm) onto gypsum board and min 2 in. (51 mm) onto the spray applied material (Item 1D) on the steel beam on both sides of wall.

RECTORSEAL — FlameSafe FS3000, [Metacaulk 1200](#), [1500](#) or Biostop 750, 800 Spray

*,+ Indicates such products shall bear the UL or cUL Certification Mark for jurisdictions employing the UL or cUL Certification (such as Canada), respectively.