

ANSI/UL1479 (ASTM E814)	CAN/ULC S115
F Rating — 2 Hr	F Rating — 2 Hr
T Ratings — 0, 1/4 and 1/2 Hr (See Item 2)	FT Ratings — 0, 1/4 and 1/2 Hr (See Item 2)
L Rating At Ambient — Less Than 1 CFM/ft <sup>2</sup>	FH Rating — 2 Hr
L Rating At 400°F — Less Than 1 CFM/ft <sup>2</sup>	FTH Ratings — 0, 1/4 and 1/2 Hr (See Item 2)
W Rating — Class 1 (See Item 2B)	L Rating At Ambient — Less Than 5.1 L/s/m <sup>2</sup>
	L Rating At 204°C — Less Than 5.1 L/s/m <sup>2</sup>

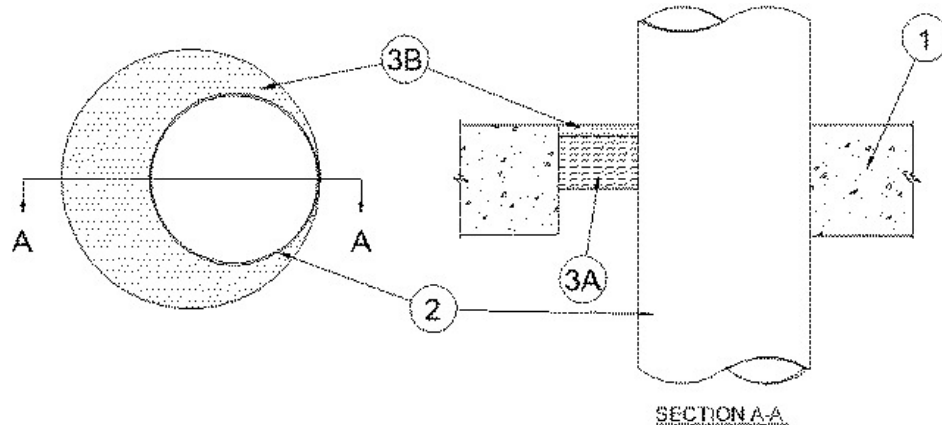

**1. Floor or Wall Assembly** — Min 4-1/2 in. (114 mm) thick reinforced lightweight or normal weight (100 -150 pcf or 1600-2400 kg/m<sup>3</sup>) concrete. Floor may also be constructed of any min 6 in. (152 mm) thick hollow-core **Precast Concrete Units\***. Wall may also be constructed of any UL Classified **Concrete Blocks\***. Max diam of opening is 11-1/4 in. (286 mm). In hollow-core floors, max diam of opening is 7 in. (178 mm).

See **Concrete Blocks (CAZT)** or **Precast Concrete Units (CFTV)** categories in the Fire Resistance Directory for names of manufacturers.

**1A. Steel Sleeve** — (Optional, not shown) - Max 11-1/4 in. (286 mm) diam sleeve fabricated from min 0.018 in. (0.46 mm) thick (28 gauge) galv sheet steel and having a min 1 in. (25 mm) lap along the longitudinal seam. Sheet steel coiled to a diam less than circular cutouts in floor or wall assembly, inserted opening and allowed to uncoil against the circular cutouts. Sleeve to be installed flush with or extending max 1 in. (25 mm) beyond each surface of the floor or wall assembly.

**1B. Steel Sleeve** — (Optional, not shown) - As an alternate to Item 1A, max 10 in. (254 mm) Schedule 5 (or heavier) steel pipe, rigid steel conduit or max 4 in. (102 mm) EMT cast or grouted into floor or wall assembly, flush with or extending a max 4 in. (102 mm) beyond each surface of the floor or wall assembly.

**2. Through Penetrant** — One metallic pipe, tubing or conduit installed concentrically or eccentrically within the firestop system. An annular space of min 0 in. (point contact) to a max 2-3/4 in. (70 mm) is required between the penetrant and the periphery of the opening or sleeve. When W Rating applies, annular space to be min 1/2 in. (13 mm). Pipe, tubing or conduit to be rigidly supported on each side of the floor or wall assembly. The following types and sizes of metallic pipes, tubing or conduit may be used:

**A. Steel Pipe** — Nom 8 in. (203 mm) diam (or smaller) Schedule 10 (or heavier) steel pipe.

**B. Copper Pipe** — Nom 4 in. (102 mm) diam (or smaller) Regular (or heavier) copper pipe.

**C. Copper Tubing** — Nom 4 in. (102 mm) diam (or smaller) Type L (or heavier) copper tubing.

**D. Conduit** — Nom 6 in. (152 mm) diam (or smaller) steel conduit or nom 4 in. diam (or smaller) steel electrical metallic tubing.

**T, FT and FTH Ratings** are 1/2 hr when annular space is 1-7/8 in. (48 mm) or less and min 1/2 in. (13 mm) thickness of sealant and min 4 in. (102 mm) thickness of mineral wool is used. T, FT and FTH Ratings are 1/4 hr when annular space is 1-7/8 in. (48 mm) or less, and min 1/4 in. (6 mm) thickness of sealant and min 2 in. (51 mm) thickness of mineral wool is used. The T, FT and FTH Ratings are 0 hr for annular spaces greater than 1-7/8 in. (48 mm). When steel sleeve is used, T, FT and FTH Ratings are 0 hr.

**3. Firestop System** — The firestop system shall consist of the following:

A. **Packing Material** — Nom 2 in. (51 mm) or 4 in. (102 mm) thickness of min 4 pcf (64 k/m<sup>3</sup>) mineral wool batt insulation firmly packed into opening as a permanent form. (See Item 2 above) Packing material to be recessed from top surface of floor/sleeve or from both surfaces of wall/sleeve or from both surfaces of hollow-core floor to accommodate the required thickness of fill material.

B. **Fill, Void or Cavity Material\* - Caulk** — Min 1/4 in. (6 mm) or 1/2 in. (13 mm) thickness of fill material applied within the annulus, flush with top surface of floor or with both surfaces of wall or with both surfaces of hollow-core floor. (See Item 2 above). When sheet metal sleeve (Item 1A) is used, fill material to be installed flush with top surface of floor or with both surfaces of wall or with both surfaces of hollow-core floor within the sleeve. When rigid steel sleeve (Item 1B) is used, fill material may be installed flush with top end of sleeve in floors or both ends of sleeve in walls.

**RECTORSEAL** — [MC 150+](#)

\*,+ Indicates such products shall bear the UL or cUL Certification Mark for jurisdictions employing the UL or cUL Certification (such as Canada), respectively.

Reprinted from the Online Certifications Directory with permission from UL. ©UL LLC