

F Rating — 2 Hr
T Ratings — 0 and 1/4 Hr (See Item 2)

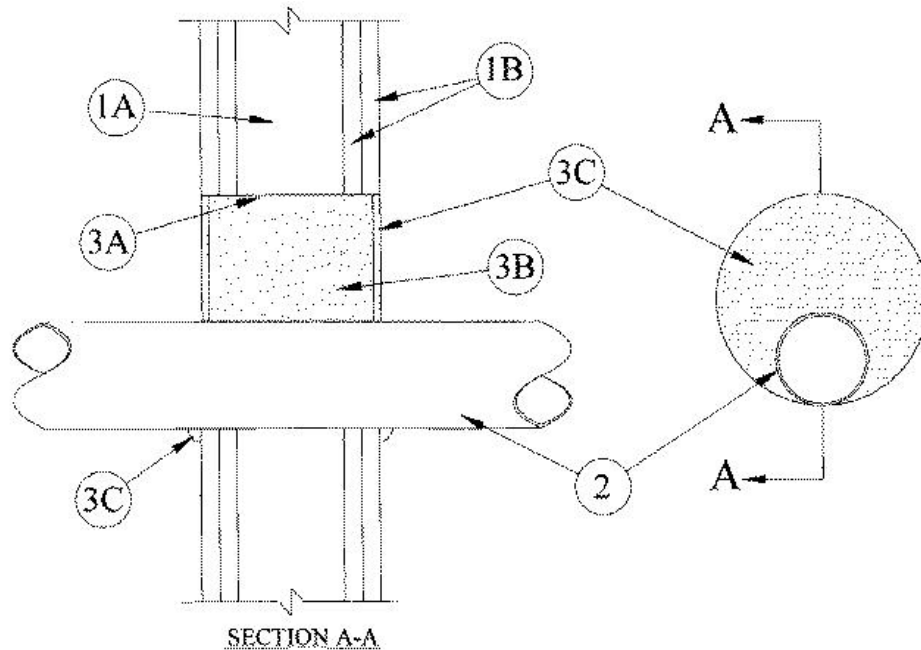

1. Wall Assembly — The fire-rated gypsum wallboard/stud wall assembly shall be constructed of the materials and in the manner specified in the individual U300 or U400 Series Wall and Partition Designs in the UL Fire Resistance Directory and shall include the following construction features:

A. Studs — Wall framing may consist of either wood studs or steel channel studs. Wood studs to consist of nom 2 by 4 in. lumber spaced 16 in. OC. Steel studs to be min 2-1/2 in. wide and spaced max 24 in. OC.

B. Gypsum Board* — Two layers of nom 5/8 in. thick gypsum wallboard, as specified in the individual Wall and Partition Design. Max diam of opening is 14-1/2 in. for wood stud walls and 20 in. for steel stud walls. Diam of circular through opening to be min 3/8 in. to max 2-3/4 in. larger than diam of through penetrants (Item 2).

2. Through-Penetrants — One metallic pipe or tubing to be installed either concentrically or eccentrically within the firestop system. Pipe or tubing to be rigidly supported on both sides of wall assembly. The following types and sizes of metallic pipes or tubing may be used:

A. Steel Pipe — 17-1/4 in. diam (or smaller) by 0.125 (or heavier) steel pipe. The annular space shall be min 0 to max 2-3/4 in. The T Rating is 1/4 hr when steel pipe is used.

B. Copper Tubing — Nom 4 in. diam (or smaller) Type L (or heavier) copper tubing. The annular space shall be min 0 to max 3 in. The T rating is 0 hr when copper tubing is used.

3. Firestop System — The firestop system shall consist of the following:

A. Steel Wire Mesh — No. 8 steel wire mesh having a min 1 in. lap along the longitudinal seam. Length of steel wire mesh to be 4-3/4 in., centered and formed to fit periphery of through opening.

B. Packing Material — Min 4-1/2 in. thickness of flexible urethane sheet firmly packed into opening as a permanent form. Packing material to be recessed from both surfaces of wall as required to accommodate the required thickness of fill material.

C. Fill, Void or Cavity Material* — Caulk — Min 1/4 in. thickness of fill material applied within the annulus, flush with both surfaces of wall. At the point contact location between pipe and wall, a min 1/2 in. diam bead of caulk shall be applied at the wall/pipe interface on both surfaces of wall assembly.

RECTORSEAL — [MC-150 Caulk](#)

*,+ Indicates such products shall bear the UL or cUL Certification Mark for jurisdictions employing the UL or cUL Certification (such as Canada), respectively.