

F Rating — 2 Hr
T Rating — 3/4 Hr

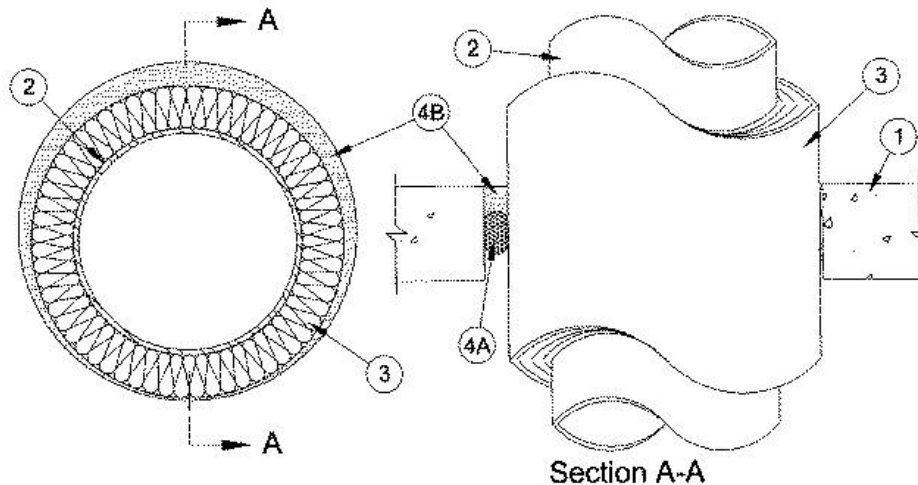

1. Floor or Wall Assembly — Min 4-1/2 in. thick reinforced lightweight or normal weight (100-150 pcf) concrete. Wall may also be constructed of any UL Classified **Concrete Blocks***. Floor may also be constructed of any 6 in. thick UL Classified hollow-core **Precast Concrete Units***. Max diam of opening is 16 in. When precast concrete units are use, max diam of opening is 7 in.

See **Concrete Blocks (CAZT)** and **Precast Concrete Units (CFTV)** categories in the Fire Resistance Directory for names of manufacturers.

2. Through Penetrants — One metallic pipe or tubing to be installed either concentrically or eccentrically within the firestop system. Pipe or tubing to be rigidly supported on both sides of floor or wall assembly. The following types and sizes of metallic pipes or tubing may be used:

A. **Steel Pipe** — Nom 10 in. diam (or smaller) Schedule 10 (or heavier) steel pipe.

B. **Iron Pipe** — Nom 10 in. diam (or smaller) cast or ductile iron pipe.

C. **Copper Tubing** — Nom 4 in. diam (or smaller) Type L (or heavier) copper tubing.

D. **Copper Pipe** — Nom 4 in. diam (or smaller) Regular (or heavier) copper pipe.

3. Pipe Covering* — Nom 2 in. thick hollow cylindrical heavy density (min 3.5 pcf) glass fiber units jacketed on the outside with an all service jacket. Longitudinal joints sealed with metal fasteners or factory-applied self-sealing lap tape. Transverse joints secured with metal fasteners or with butt tape supplied with the product. The annular space between insulated pipe and periphery of opening shall be min 1/4 in. to max 1 in.

See **Pipe and Equipment Covering — Materials (BRGU)** category in the Building Materials Directory for names of manufacturers. Any pipe covering material meeting the above specifications and bearing the UL Classification Marking with a Flame Spread Index of 25 or less and a Smoke Developed Index of 50 or less may be used.

4. Firestop System — The firestop system shall consist of the following:

A. **Packing Material** — Foam backer rod firmly packed into opening as a permanent form. Packing material to be recessed from top surface of solid concrete floor or from both surfaces of wall or hollow-core floor as required to accommodate the required thickness of fill material.

B. **Fill, Void or Cavity Material*** — **Caulk** — Min 1-1/4 in. thickness of fill material applied within the annulus, flush with top surface of solid concrete floor or with both surfaces of wall or hollow-core floor.

RECTORSEAL — [Metacaulk 1000](#)

*,+ Indicates such products shall bear the UL or cUL Certification Mark for jurisdictions employing the UL or cUL Certification (such as Canada), respectively.

Reprinted from the Online Certifications Directory with permission from UL. ©UL LLC