

ANSI/UL1479 (ASTM E814)	CAN/ULC S115
F Ratings — 1 and 2 Hr (See Item 1)	F Ratings — 1 and 2 Hr (See Item 1)
T Ratings — 0, 3/4, 1 and 1-1/2 Hr (See Item 1)	FT Ratings — 0, 3/4, 1 and 1-1/2 Hr (See Item 1)
L Rating At Ambient — Less Than 1 CFM/sq ft	FH Ratings — 1 and 2 Hr (See Item 1)
L Rating At 400 F — Less Than 1 CFM/sq ft	FTH Ratings — 0, 3/4, 1 and 1-1/2 Hr (See Item 1)
	L Rating At Ambient — Less Than 1 CFM/sq ft
	L Rating At 400 F — Less Than 1 CFM/sq ft

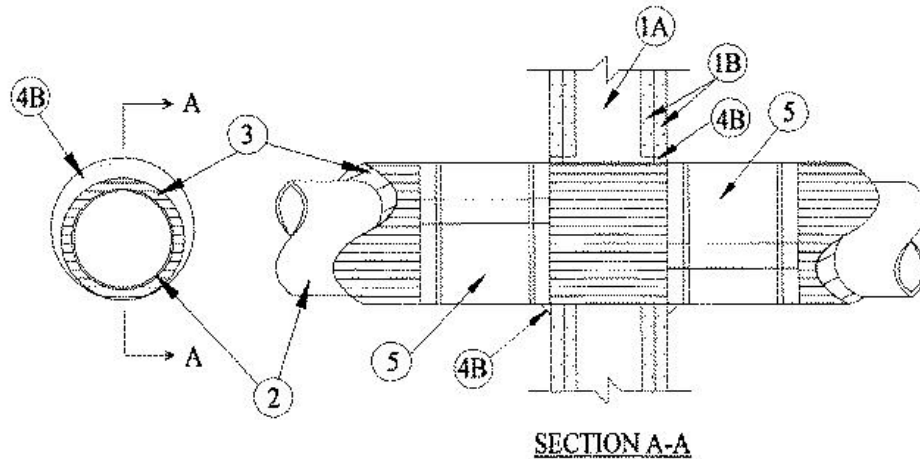

1. Wall Assembly — The 1 or 2 hr fire-rated gypsum board/stud wall assembly shall be constructed of the materials and in the manner described in the individual U300, U400 or V400 Series Wall and Partition Design in the UL Fire Resistance Directory and shall include the following construction features:

A. Studs — Wall framing may consist of either wood studs or steel channel studs. Wood studs to consist of nom 2 by 4 in. (51 by 102 mm) lumber spaced 16 in. (406 mm) OC. Steel studs to be min 3-5/8 in. (92 mm) wide and spaced max 24 in. (610 mm) OC.

B. Gypsum Board* — 5/8 in. (16 mm) thick, 4 ft (1.2 m) wide with square or tapered edges. The gypsum board type, thickness, number of layers, fastener type and sheet orientation shall be as specified in the individual U300, U400 or V400 Series Design in the UL Fire Resistance Directory. Max diam of opening is 18 in. (457 mm) for steel stud walls. Max diam of opening is 14-1/2 in. (368 mm) for wood stud walls.

The hourly Ratings of the firestop system are dependent on the hourly fire rating of the wall assembly in which it is installed as shown in the table below:

Rating of Wall Hr	Penetrant Diam/Type	F and FH Ratings, Hr	T, FT and FTH Ratings Hr	Sealant
2	10 in. (254 mm) steel & iron	2	1-1/2	FS1900 series, Metacaulk 1000 , Metacaulk 350i , Biostop 350i or Biostop 500+
2	6 in. (152 mm) copper, steel or iron	2	1	FS 900+
1	6 in. (152 mm) copper, steel or iron	1	0	FS 900+
1	10 in. (254 mm) steel & iron	1	3/4	FS1900 series, Metacaulk 1000 , Metacaulk 350i , Biostop 350i or Biostop 500+

2. **Through Penetrant** — One metallic pipe to be installed either concentrically or eccentrically within the firestop system. Pipe to be rigidly supported on both sides of wall assembly. The following types and sizes of metallic pipes may be used:

A. **Steel Pipe** — Nom 10 in. (254 mm) diam (or smaller) Schedule 10 (or heavier) steel pipe.

B. **Iron Pipe** — Nom 10 in. (254 mm) diam (or smaller) cast or ductile iron pipe.

C. **Copper Tubing** — Nom 6 in. (152 mm) diam (or smaller) Type L (or heavier) copper tubing.

3. **Through Penetrating Product*** — **Cellular Glass Insulation** — Nom 3 in. (76 mm) thick cellular glass units sized to the outside diam of the through-penetrant and supplied in nom 24 in. (610 mm) long half sections or nom 18 in. (457 mm) long segments. Pipe insulation installed on pipe in accordance with the manufacturer's instructions. The annular space between insulated pipes and periphery of opening shall be min 0 in. (point contact) to max 1-1/4 in. (32 mm).

4. **Firestop System** — The firestop system shall consist of the following:

A. **Forms** — (Not Shown) — Used to prevent the leakage of fill material during installation in 2 hr fire-rated assemblies. Forms to be rigid sheet material or polyurethane backer rod, cut to fit the contour of the insulated through penetrant and friction fitted into the opening on both sides of wall. Forms to be recessed from both surfaces of wall as required to accommodate the required thickness of fill material.

B. **Fill, Void or Cavity Materials*** — **Sealant** — Min 5/8 in. (16 mm) thickness of fill material applied within the annulus flush with both surfaces of wall. After installation of the metal jacket (Item 5), min 3/8 in. (10 mm) diam bead of fill material shall be applied to the metal jacketing/fill material interface on both sides of wall.

RECTORSEAL — FlameSafe FS 900+, FS1900, FS1901, FS1905, FS1929, [Metacaulk MC 150+](#), [Metacaulk 1000](#), [Metacaulk 350i](#), Biostop BF [150+](#), Biostop 350i or Biostop 500+

5. **Metal Jacket** — (Not required for FS900+) — Min 12 in. (305 mm) long jacket formed of min 0.010 in. (0.25 mm) thick aluminum sheet cut to wrap tightly around the pipe insulation with a min 2 in. (51 mm) lap and secured using 1/2 in. (13 mm) wide by 0.028 in. (0.71 mm) thick stainless steel hose clamps. Clamps to be located within 2 in. (51 mm) of each end of the jacket and spaced max 10 in. (254 mm) OC. Jacket to be installed with edge abutting surface of fill material (Item 4B) on each side of wall. Metal jacket to be used in addition to any other jacketing material which may be required or desired on the pipe insulation.

*,+ Indicates such products shall bear the UL or cUL Certification Mark for jurisdictions employing the UL or cUL Certification (such as Canada), respectively.

Reprinted from the Online Certifications Directory with permission from UL. ©UL LLC