

F Rating — 4 Hr  
T Rating — 0 Hr

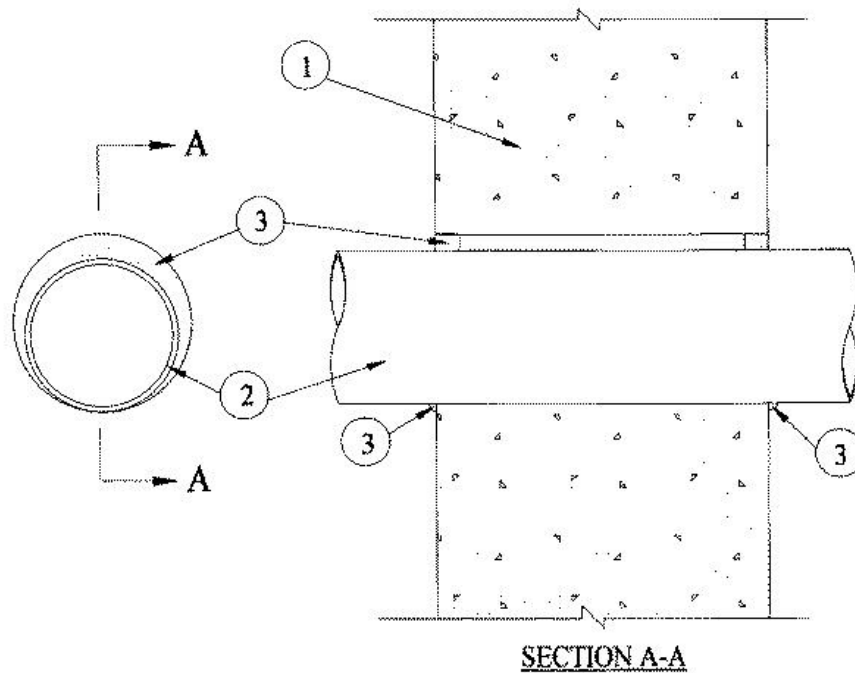

1. **Wall Assembly** — Min 5-5/8 in. thick reinforced lightweight or normal weight (100-150 pcf) concrete. Wall may also be constructed of any UL Classified **Concrete Blocks\***. Max diam of opening is 9 in. See **Concrete Blocks** (CAZT) category in the Fire Resistance Directory for names of manufacturers.

2. **Through Penetrants** — One metallic pipe, conduit or tubing to be installed either concentrically or eccentrically within the firestop system. The annular space between pipes, conduits or tubing and periphery of opening shall be min 0 in. (point contact) to max 3/8 in. Pipe, conduit or tubing to be rigidly supported on both sides of floor or wall assembly. The following types and sizes of metallic pipes, conduits or tubing may be used:

A. **Steel Pipe** — Nom 8 in. diam (or smaller) Schedule 40 (or heavier) steel pipe.

B. **Iron Pipe** — Nom 8 in. diam (or smaller) cast or ductile iron pipe.

C. **Conduit** — Nom 4 in. diam (or smaller) steel electrical metallic tubing or nom 6 in. diam (or smaller) steel conduit.

D. **Copper Tubing** — Nom 4 in. diam (or smaller) Type L (or heavier) copper tubing.

E. **Copper Pipe** — Nom 4 in. diam (or smaller) Regular (or heavier) copper pipe.

3. **Fill, Void or Cavity Material\* — Caulk** — Min 1 in. thickness of fill material applied within the annulus, flush with both surfaces of wall. A min 1/4 in. diam bead of caulk shall be applied to the pipe/concrete interface at the point contact location on both sides of wall.

**RECTORSEAL** — [Metacaulk 1000](#)

\*,+ Indicates such products shall bear the UL or cUL Certification Mark for jurisdictions employing the UL or cUL Certification (such as Canada), respectively.

Reprinted from the Online Certifications Directory with permission from UL. ©UL LLC