

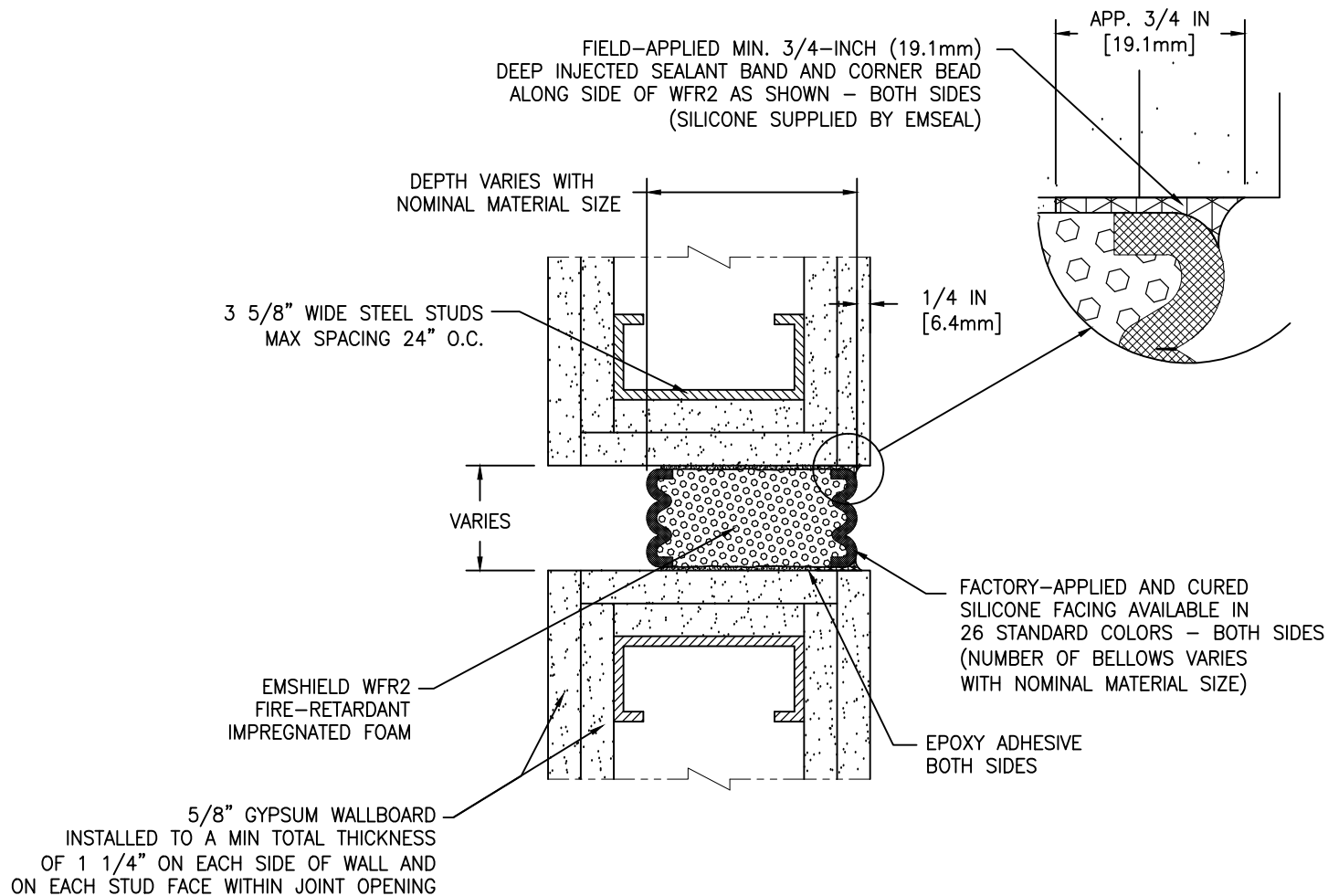

System # FF-D-()
 System # ()
 UL CERTIFICATION
 VARIES WITH NOMINAL
 MATERIAL SIZE



MOVEMENT: ±50% (TOTAL 100%) OF NOMINAL MATERIAL SIZE

EMSEAL JOINT SYSTEMS LTD.

EMSHIELD WFR2 WALL TO WALL GYPSUM STEEL STUDS - TYPICAL

THIS DOCUMENT CONTAINS INFORMATION OF A CONFIDENTIAL NATURE AND IS PROPRIETARY TO EMSEAL JOINT SYSTEMS LTD. ANY UNAUTHORIZED USE WILL BE PROSECUTED. THIS DRAWING IS PROTECTED BY COPYRIGHT, THE RIGHT TO REPRODUCE IN ANY FORM BEING THE EXCLUSIVE RIGHT OF EMSEAL JOINT SYSTEMS LTD. ANY UNAUTHORIZED REPRODUCTION WHETHER IN TWO OR THREE DIMENSIONS WILL BE PROSECUTED. © 2014 EMSEAL JOINT SYSTEMS LTD.

DRAWN BY:	DATE:	SCALE:	SHEET
ORK	2016/08/22	N.T.S.	No: 1 OF 1
PART NUMBER:			
WFR2_WW_GYP_STEEL_STUDS_TYPICAL			