

ANSI/UL1479 (ASTM E814)	CAN/ULC S115
F Ratings - 1 and 2 Hr (See Item 1)	F Ratings - 1 and 2 Hr (See Item 1)
T Ratings - 1/2 , 1 and 2 Hr (See Item 1)	FT Ratings - 1/2 , 1 and 2 Hr (See Item 1)
L Rating At Ambient - Less Than 1 CFM/sq ft	FH Ratings - 1 and 2 Hr (See Item 1)
L Rating At 400 F - Less Than 1 CFM/sq ft	FTH Ratings - 1/2 , 1 and 2 Hr (See Item 1)
	L Rating At Ambient - Less Than 1 CFM/sq ft
	L Rating At 400 F - Less Than 1 CFM/sq ft

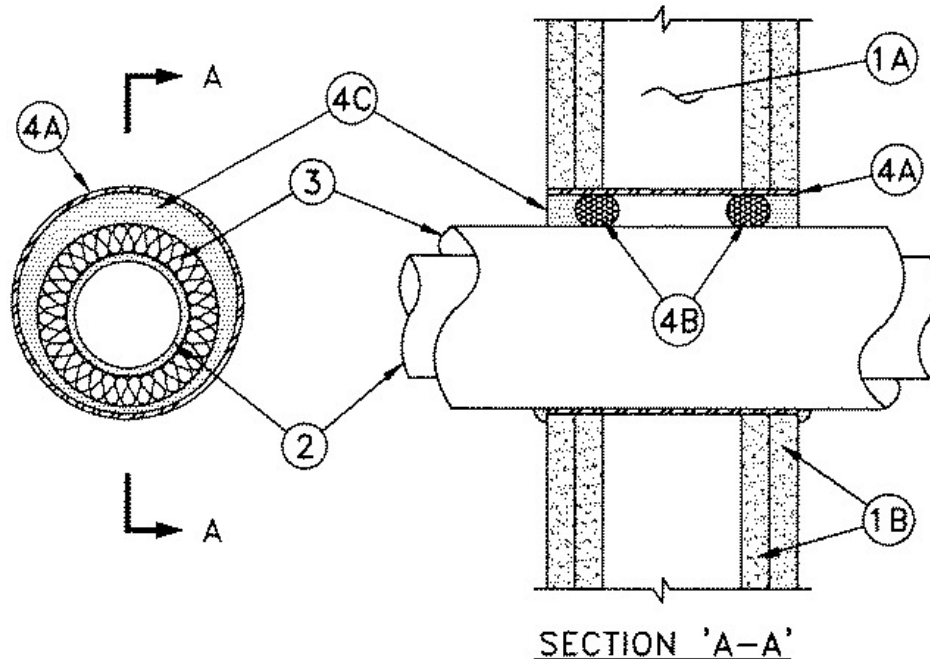

1. Wall Assembly — The 1 or 2 hr fire-rated gypsum board/stud wall assembly shall be constructed of the materials and in the manner described in the individual U300, U400 or V400 Series Wall and Partition Designs in the UL Fire Resistance Directory and shall include the following construction features:

A. Studs — Wall framing shall consist of either wood studs or steel channel studs. Wood studs to consist of nom 2 by 4 in. (51 by 102 mm) lumber spaced 16 in. (406 mm) OC. Steel studs to be min 3-5/8 in. (92 mm) wide and spaced 24 in. (610 mm) OC.

B. Gypsum Board* — 5/8 in. (16 mm) thick, 4 ft (1.2 m) wide with square or tapered edges. The gypsum board type, thickness, number of layers, fastener type and sheet orientation shall be as specified in the individual U300 or U400 Series Designs in the UL Fire Resistance Directory. Max diam of opening in wood stud walls is 14-1/2 in. (368 mm). Max diam of opening in steel stud walls is 18-3/4 in. (476 mm).

The hourly F Rating of the firestop system is equal to the hourly fire rating of the wall assembly in which it is installed.

When copper pipe or tubing is used (see Item 2), the hourly T Rating is 1/2 hr and 1 hr for 1 and 2 hr rated assemblies, respectively.

When iron pipe or steel pipe is used (see Item 2), the hourly T Rating is 1 hr and 2 hr for 1 and 2 hr rated assemblies, respectively.

2. Through Penetrants — One metallic pipe or tube installed concentrically or eccentrically within the firestop system. Pipe or tube to be rigidly supported on both sides of the wall. The following types and sizes of through penetrants may be used:

A. Steel Pipe — Nom 12 in. (305 mm) diam (or smaller) Schedule 40 (or heavier) steel pipe.

B. Iron Pipe — Nom 12 in. (305 mm) diam (or smaller) cast or ductile iron pipe.

C. Copper Tubing — Nom 6 in. (152 mm) diam (or smaller) Type L (or heavier) copper tubing.

D. **Copper Pipe** — Nom 6 in. (152 mm) diam (or smaller) Regular (or heavier) copper pipe.

3. **Pipe Covering*** — One of the following types of pipe coverings shall be used:

A. **Pipe and Equipment Covering Materials*** — Nom 2 in. (51 mm) thick hollow cylindrical glass fiber units, nom 3.5 pcf (56 kg/m³) density, jacketed on the outside with an all service jacket. Longitudinal joints sealed with metal fasteners or factory-applied self-sealing lap tape. Transverse joints secured with metal fasteners or butt tape supplied with the product. The annular space between the insulated through penetrant and the metallic sleeve (Item 4A) shall be min 0 in. (point contact) to max 2 in. (51 mm).

See **Pipe and Equipment Covering Materials*** (BRGU) category in the Building Materials Directory for names of manufacturers. Any pipe covering material meeting the above specifications and bearing the UL Classification Marking with a Flame Spread Index of 25 or less and a Smoke Developed Index of 50 or less may be used.

B. **Pipe and Equipment Covering Materials*** — Nom 2 in. (51 mm) thick unfaced mineral fiber pipe insulation having a nom density of 3.5 pcf (56 kg/m³) (or heavier) and sized to the outside diam of the pipe or tube. Pipe insulation secured with min 8 AWG steel wire spaced 12 in. (305 mm) OC. The annular space between insulated penetrating item and the metallic sleeve (Item 4A) shall be min 0 in. (point contact) to max 2 in. (51 mm).

C. **Sheathing Material** — Used in conjunction with Item 3B. Foil-scrim-kraft or all service jacket material shall be wrapped around the outer circumference of the pipe insulation (Item 3B) with the kraft side exposed. Longitudinal and transverse joints sealed with metal fasteners or butt tape.

See **Sheathing Materials*** (BVDV) category in the Building Materials Directory for names of manufacturers. Any sheathing material meeting the above specifications and bearing the UL Classification Marking with a Flame Spread Index of 25 or less and a Smoke Developed Index of 50 or less may be used.

4. **Firestop System** — The firestop system shall consist of the following:

A. **Metallic Sleeve** — Cylindrical sleeve fabricated from min 0018 in. (0.46 mm) thick (No. 28 gauge) galv sheet steel and having a min 1 in. (25 mm) lap along the longitudinal seam. Length of steel sleeve to be equal to thickness of wall. The inside diam of sleeve shall be min 1 in. (25 mm) larger than the outside diam of pipe covering. Sleeve installed by coiling the sheet steel to a diam smaller than the through opening, inserting the coil through the opening and releasing the coil to let it uncoil against the circular cutouts in the gypsum board. Sleeve to be tightly fitted in wall opening with no annular space. The annular space between the insulated through penetrant and the sleeve shall be min 0 in. (point of contact) to max 2 in. (51 mm).

B. **Packing Material** — Nom 1 in. (25 mm) foam backer rod firmly packed into the opening as a permanent form in 2 hr fire-rated wall assemblies to prevent leakage of fill material during installation. Packing material to be recessed from both surfaces of wall as required to accommodate the required thickness of fill material.

C. **Fill, Void or Cavity Material* - Sealant** — Min 1 in. (25 mm) thickness of fill material applied within annulus, flush with each surface of wall. At point contact location, a min 3/8 in. (10 mm) bead of fill material shall be applied to the wall/sleeve/pipe covering interface on both surfaces of the wall.

RECTORSEAL — FlameSafe® FS900+, [Metacaulk MC 150+](#), Biostop BF [150+](#)

*,+ Indicates such products shall bear the UL or cUL Certification Mark for jurisdictions employing the UL or cUL Certification (such as Canada), respectively.

Reprinted from the Online Certifications Directory with permission from UL. ©UL LLC