

ANSI/UL1479 (ASTM E814)	CAN/ULC S115
F Rating — 2 Hr	F Rating — 2 Hr
T Rating — 0 Hr	FT Rating — 0 Hr
	FH Rating — 2 Hr
	FTH Rating — 0 Hr

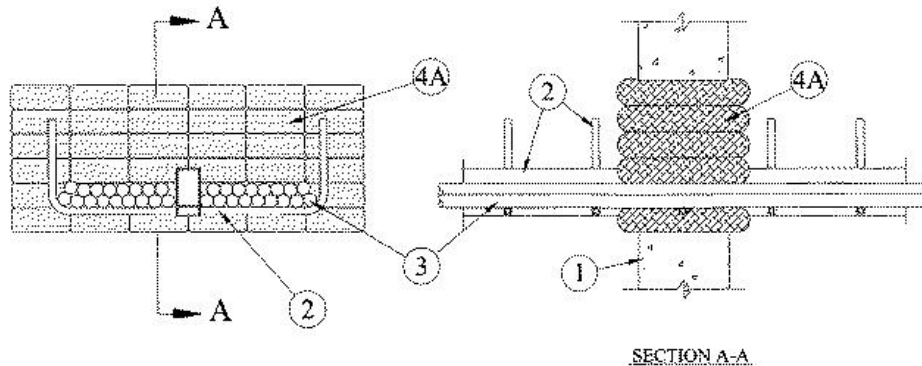

1. **Wall Assembly** — Min 6 in. (152 mm) thick reinforced lightweight or normal weight (100-150 pcf or 1600-2400 kg/m³) concrete. Wall may also be constructed of any UL Classified **Concrete Blocks***. Max area of opening is 280 sq in. (1806 cm²) with max dimensions of 28 in. (711 mm).

See **Concrete Blocks** (CAZT) category in the Fire Resistance Directory for names of manufacturers.

2. **Cable Tray*** — Max 24 in. (610 mm) wide by max 6 in. (152 mm) deep spine cable tray. The 1 in. (25 mm) wide by 4 in. (102 mm) deep tubular spine to be formed of min 0.081 (2 mm) thick extruded aluminum. The 6 in. (152 mm) deep "U" shaped rungs spaced 6 in. (152 mm) OC. Formed from 1/2 by 1/2 in. (13 by 13 mm) extruded aluminum. One cable tray to be installed in the opening. The annular space between the cable tray and the periphery of opening shall be a min of 1 in. (25 mm) to a max 3 in. (76 mm). Cable tray to be rigidly supported on both sides of wall assembly.

3. **Cables** — Max 3 in. (76 mm) cable loading depth within the cable tray. Any combination of the following types and sizes of cables may be used:

- A. Max 200 pair No. 24 AWG (or smaller) copper conductor telephone cable with polyvinyl chloride (PVC) insulation and jacket materials.
- B. Max 72 fibers — 62.5/125 fiber optic cable with PVC insulation and jacket materials.
- C. Max RG/U (or smaller) coaxial copper conductor cable with fluorinated ethylene insulation and PVC jacket materials.
- D. Max 4 pair No. 24 AWG (or smaller) copper conductor Category 3 telephone cable with PVC insulation and jacket materials.

4. **Firestop System** — The firestop system shall consist of the following:

A. **Fill, Void or Cavity Material* — Sealant** — (Not Shown) - Min 1/2 in. (13 mm) thickness of fill material applied to seal any voids between cables and between cables and cable tray within the center of the opening. After the installation of the pillows (Item 4B), additional sealant applied to seal any voids between the cables and pillows and between the pillows on both sides of wall assembly.

RECTORSEAL — FlameSafe FS1900, FS1901, FS1905, FS1929, [Metacaulk 1000](#), [Metacaulk 350i](#), Biostop 350i or Biostop 500+

B. **Fill, Void or Cavity Material* — Pillows** — Max 9 in. (229 mm) long by 6 in. (152 mm) wide by 2 in. (51 mm) thick pillow-like material tightly packed into opening to fill the annular space between cables, between cables and periphery of opening and between cable tray and periphery of opening. Pillows to be installed with 6 in. (152 mm) dimension projecting through wall and centered within the opening.

RECTORSEAL — FlameSafe® Pillows, [Metacaulk Pillows](#) or Biostop Pillows

*,+ Indicates such products shall bear the UL or cUL Certification Mark for jurisdictions employing the UL or cUL Certification (such as Canada), respectively.



Reprinted from the Online Certifications Directory with permission from UL. ©UL LLC