

ANSI/UL1479 (ASTM E814)	CAN/ULC S115
F Ratings — 1 and 2 Hr (See Item 1)	F Ratings — 1 and 2 Hr (See Item 1)
T Ratings — 1 and 2 Hr (See Item 1)	FT Ratings — 1 and 2 Hr (See Item 1)
	FH Ratings — 1 and 2 Hr (See Item 1)
	FTH Ratings — 1 and 2 Hr (See Item 1)

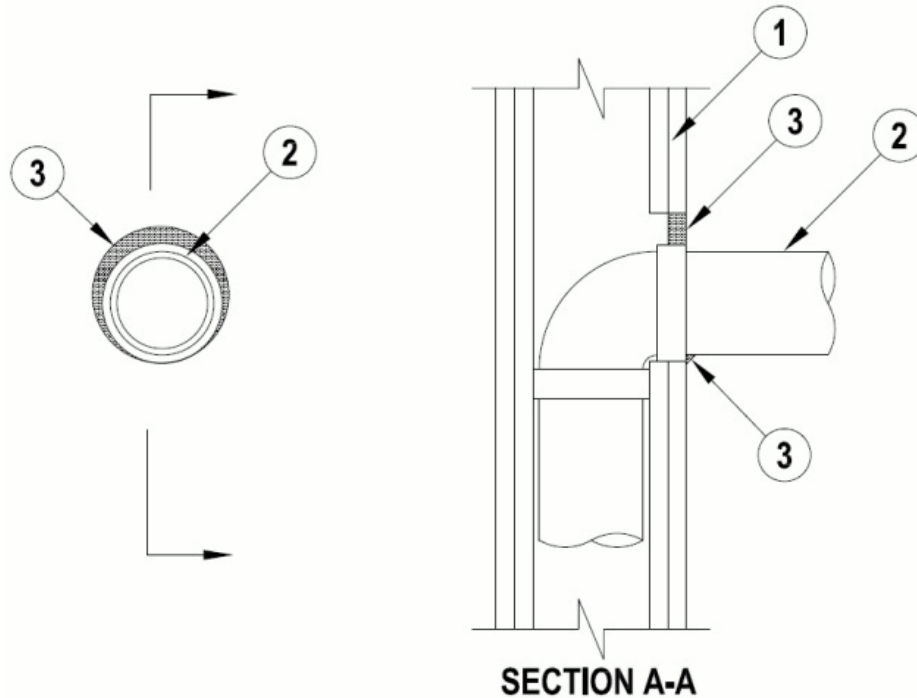

**1. Wall Assembly** — The 1 or 2 hr fire rated gypsum board/stud wall assembly shall be constructed of the materials and in the manner specified in the individual U300, U400, V400 or W400 Series Wall and Partition Designs in the UL Fire Resistance Directory and shall include the following construction features:

**A. Studs** — Wall framing may consist of either wood studs or steel channel studs. Wood studs to consist of nom 2 by 4 in. (51 by 102 mm) lumber spaced 16 in. (406 mm) OC. Steel studs to be min 3-5/8 in. (91 mm) wide and spaced max 24 in. (610 mm) OC.

**B. Gypsum Board\*** — One or two layers of nom 5/8 in. (16 mm) thick gypsum board as specified in the individual Wall and Partition Design. Opening may be circular or elliptical in shape. Max dimension of opening is 6-1/2 in. (165 mm) with max area of 17.87 in<sup>2</sup> (115.3 cm<sup>2</sup>).

**The hourly F, T and FH and FTH Ratings of the firestop system are equal to the hourly fire rating of the wall assembly.**

**2. Through penetrants** — One metallic pipe, tubing or conduit to be installed either concentrically or eccentrically within the firestop system. The penetrant may be installed at an angle not greater than 45 degrees from perpendicular. The annular space shall be 0 in. (point contact) to 1 in. (25 mm). Pipe, tubing or conduit to be rigidly supported on the penetrated side of the wall assembly. The following types and sizes of metallic pipes, tubing or conduits may be used:

**A. Steel pipe** — Nom 3 in. (76 mm) diam (or smaller) Schedule 5 (or heavier) steel pipe.

**B. Conduit** — Nom 3 in. (76 mm) diam (or smaller) steel electrical metallic tubing (EMT), nom 3 in. (76 mm) diam (or smaller) steel conduit or nom 1 in. (25 mm) diam (or smaller) flexible steel conduit.

**C. Copper Tubing** — Nom 1 in. (25 mm) diam (or smaller) Type L (or heavier) copper tubing.

**D. Copper Pipe** — Nom 1 in. (25 mm) diam (or smaller) Regular (or heavier) copper pipe.

**3. Fill, Void or Cavity Material\*— Sealant** — Min 5/8 in. (16 mm) thickness of fill material applied within the annulus, flush with surface of wall. Min 1/4 in. (6 mm) diam bead of sealant applied at point contact location.

**RECTORSEAL** — [Metacaulk 150+](#), [Metacaulk 1000](#), [Metacaulk Fire Rated Putty](#), [Biostop 150+](#), [Biostop 500+](#), [Biostop Fire Rated Putty](#)



---

\*,+ Indicates such products shall bear the UL or cUL Certification Mark for jurisdictions employing the UL or cUL Certification (such as Canada), respectively.

Reprinted from the Online Certifications Directory with permission from UL. ©UL LLC