

F Rating — 2 Hr
T Rating — 1-3/4 Hr

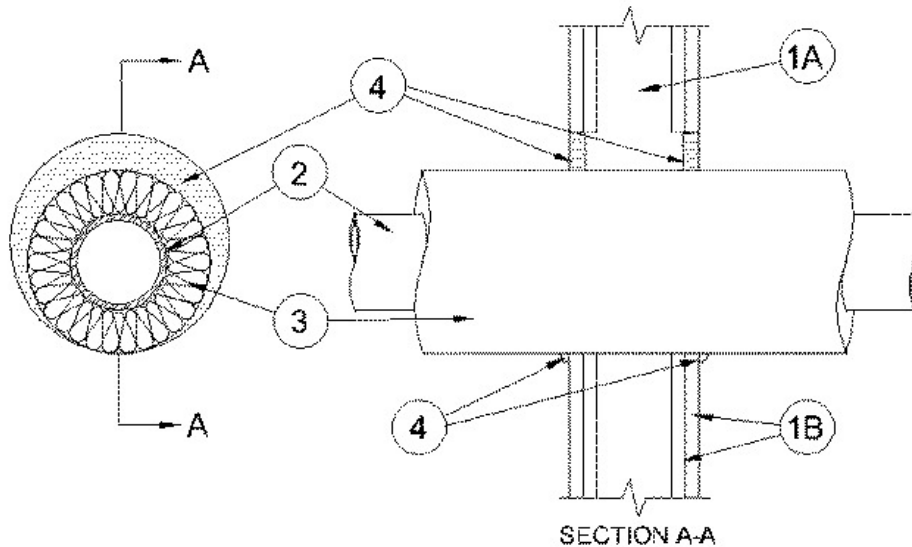

1. Wall Assembly — The 2 hr fire-rated gypsum board/steel stud wall assembly shall be constructed of the materials and in the manner specified in the individual U400 Series Wall and Partition Designs in the UL Fire Resistance Directory and shall include the following construction features:

A. **Studs** — Wall framing shall consist of steel channel studs. Steel studs to be min 3-1/2 in. wide and spaced max 24 in. OC.

B. **Gypsum Board*** — Two layers of min 5/8 in. thick gypsum board. The gypsum board type, thickness, number of layers and orientation shall be as specified in the individual Wall and Partition Design. Max diam of opening is 8-1/2,

2. Through Penetrants — One metallic pipe or tubing to be installed either concentrically or eccentrically within the firestop system. Pipe or tubing to be rigidly supported on both sides of floor or wall assembly. The following types and sizes of metallic pipes or tubing may be used:

A. **Steel Pipe** — Nom 4 in. diam (or smaller) Schedule 40 (or heavier) steel pipe.

B. **Iron Pipe** — Nom 4 in. diam (or smaller) cast or ductile iron pipe.

C. **Copper Tubing** — Nom 4 in. diam (or smaller) Type L (or heavier) copper tubing.

D. **Copper Pipe** — Nom 4 in. diam (or smaller) Regular (or heavier) copper pipe.

3. Pipe Covering* — Nom 1-1/2 in. thick hollow cylindrical heavy density (min 3.5 pcf) glass fiber units jacketed on the outside with an all service jacket. Longitudinal joints sealed with metal fasteners or factory-applied self-sealing lap tape. Transverse joints secured with metal fasteners or with butt tape supplied with the product. The annular space between insulated pipe and periphery of opening shall be min 0 in. (point contact) to max 1-3/8 in.

See Pipe and Equipment Covering - Materials(BRGU) category in the Building Materials Directory for names of manufacturers. Any pipe covering material meeting the above specifications and bearing the UL Classification Marking with a Flame Spread Index of 25 or less and a Smoke Developed Index of 50 or less may be used.

4. Fill, Void or Cavity Material* - Caulk — Min 3/4 in. thickness of fill material applied within the annulus, flush with both surfaces of wall. At point contact location, between gypsum board and insulated pipe, a min 1/4 in. diam bead of fill material shall be applied to the gypsum board/insulated pipe interface on both surfaces of wall.

RECTORSEAL — [Metacaulk 1000](#)

*,+ Indicates such products shall bear the UL or cUL Certification Mark for jurisdictions employing the UL or cUL Certification (such as Canada), respectively.

Reprinted from the Online Certifications Directory with permission from UL. ©UL LLC