

F Rating — 3 Hr
 T Rating — 1/2 Hr
 L Rating At Ambient — 2.8 CFM/sq ft
 L Rating At 400 F — Less Than 1 CFM/sq ft

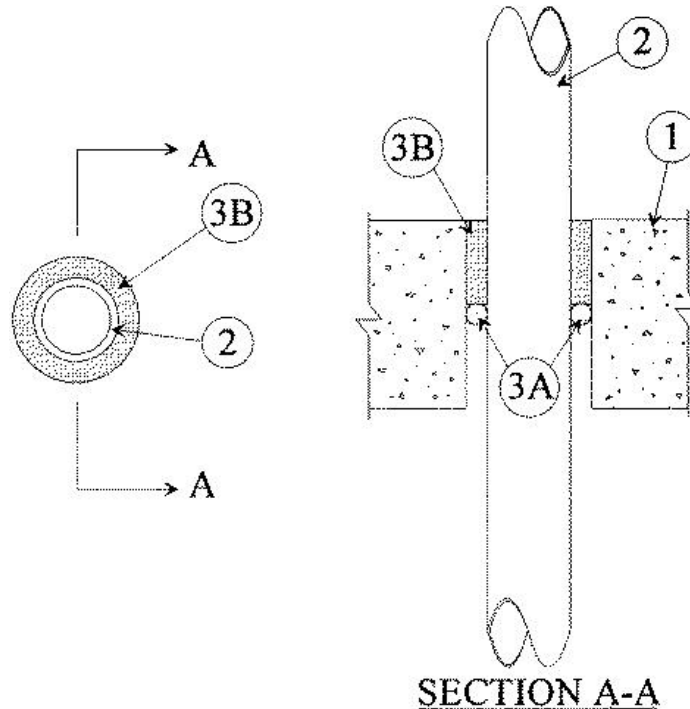

1. **Floor or Wall Assembly** — Min 4-1/2 in. thick reinforced lightweight or normal weight (100-150 pcf) concrete. Wall may also be constructed of any UL Classified **Concrete Blocks***. Max diam of opening is 4 in. See **Concrete Blocks** (CAZT) category in the Fire Resistance Directory for names of manufacturers.

2. **Nonmetallic Pipe** — One nonmetallic pipe to be centered within the firestop system. A nom annular space of 7/8 in. is required within the firestop system. Pipe to be rigidly supported on both sides of floor or wall assembly. The following types and sizes of nonmetallic may be used:

A. **Polyvinyl Chloride (PVC) Pipe** — Nom 2 in. diam (or smaller) Schedule 40 PVC pipe for use in closed (process or supply) or vented (drain, waste or vent) piping systems.

B. **Chlorinated Polyvinyl Chloride (CPVC) Pipe** — Nom 2 in. diam (or smaller) SDR 17 CPVC pipe for use in closed (process or supply) or vented (drain, waste or vent) piping systems.

3. **Firestop System** — The firestop system shall consist of the following:

A. **Packing Material** — (Optional) — Foam backer rod firmly packed into opening as a permanent form. Packing material to be recessed from top surface of floor or from both surfaces of wall as required to accommodate the required thickness of fill material.

B. **Fill, Void or Cavity Material* — Sealant** — Min 2 in. thickness of fill material applied within the annulus, flush with top surface of floor or with both surfaces of wall.

RECTORSEAL — [Metacaulk 1000](#).

*,+ Indicates such products shall bear the UL or cUL Certification Mark for jurisdictions employing the UL or cUL Certification (such as Canada), respectively.

Reprinted from the Online Certifications Directory with permission from UL. ©UL LLC