

F Rating — 2 Hr  
T Rating — 1 Hr

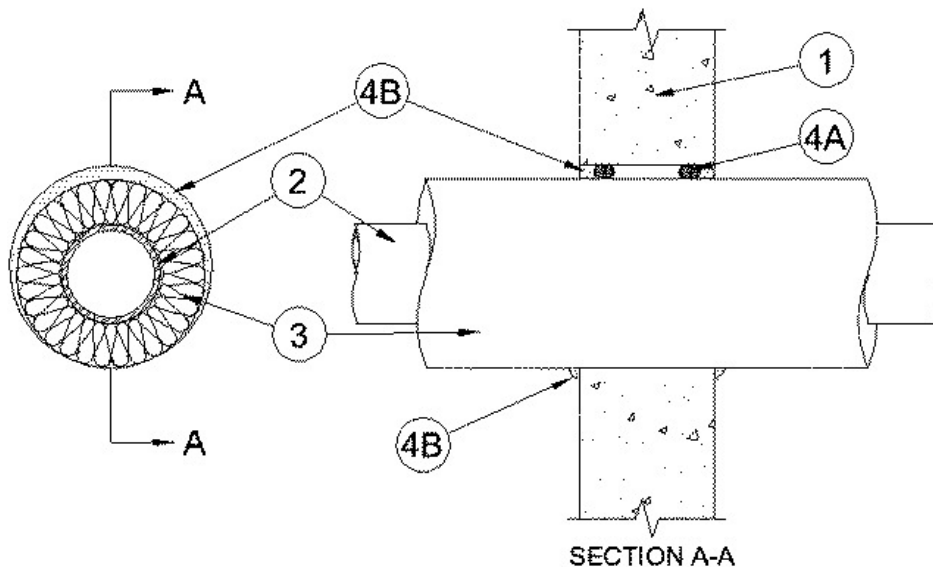

**1. Wall Assembly** — Min 6 in. thick reinforced lightweight or normal weight (100-150 pcf) concrete. Wall may also be constructed of any UL Classified Concrete Blocks\*. Max diam of opening is 9 in.

See **Concrete Blocks** (CAZT) category in the Fire Resistance Directory for names of manufacturers.

**2. Through Penetrants** — One metallic pipe or tubing to be centered within the firestop system. Pipe or tubing to be rigidly supported on both sides of wall assembly. The following types and sizes of metallic pipes or tubing may be used:

A. **Steel Pipe** — Nom 4 in. diam (or smaller) Schedule 10 (or heavier) steel pipe.

B. **Copper Tubing** — Nom 4 in. diam (or smaller) Type L (or heavier) copper tubing.

C. **Copper Pipe** — Nom 4 in. diam (or smaller) Regular (or heavier) copper pipe.

**3. Pipe Covering\*** — Nom 1-1/2 or 2 in. thick hollow cylindrical glass fiber units with an all service jacket. Longitudinal joints sealed with metal fasteners or factory-applied self-sealing lap tape. Transverse joints secured with metal fasteners or with butt tape supplied with the product. A min annular space of min 0 (point contact) to max 1/2 in. is required within the firestop system.

See **Pipe and Equipment Covering Materials-** (BRGU) category in the Building Materials Directory for names of manufacturers. Any pipe covering meeting the above specifications and bearing the UL Classification Marking with a Flame Spread Index of 25 or less and a Smoke Developed Index of 50 or less may be used.

**4. Firestop System** — The firestop system shall consist of the following:

A. **Packing Material** — Foam backer rod firmly packed into opening as a permanent form. Packing material to be recessed from each surface of the wall to accommodate the required thickness of fill material.

B. **Fill, Void or Cavity Material\* - Caulk** — Min 1/2 or 3/4 in. thickness of fill material applied within the annulus, flush with both surfaces of wall. When 1-1/2 in. thick pipe covering is used, thickness of fill material shall be 1/2 in. depth. When pipe covering is 2 in. thick, thickness of fill material shall be 3/4 in. A min 1/4 in. diam bead of fill material shall be applied at the pipe covering/gypsum board interface on both surfaces of wall.

**RECTORSEAL** — [Metacaulk 1000](#)

\*,+ Indicates such products shall bear the UL or cUL Certification Mark for jurisdictions employing the UL or cUL Certification (such as Canada), respectively.

Reprinted from the Online Certifications Directory with permission from UL. ©UL LLC