

ANSI/UL1479 (ASTM E814)	CAN/ULC S115
F Ratings — 1 and 2 Hr (See Item 1)	F Rating — 1 and 2 Hr (See Item 1)
T Rating — 1/2 Hr	FT Rating — 1/2 Hr
	FH Rating — 1 and 2 Hr (See Item 1)
	FTH Rating — 1/2 Hr

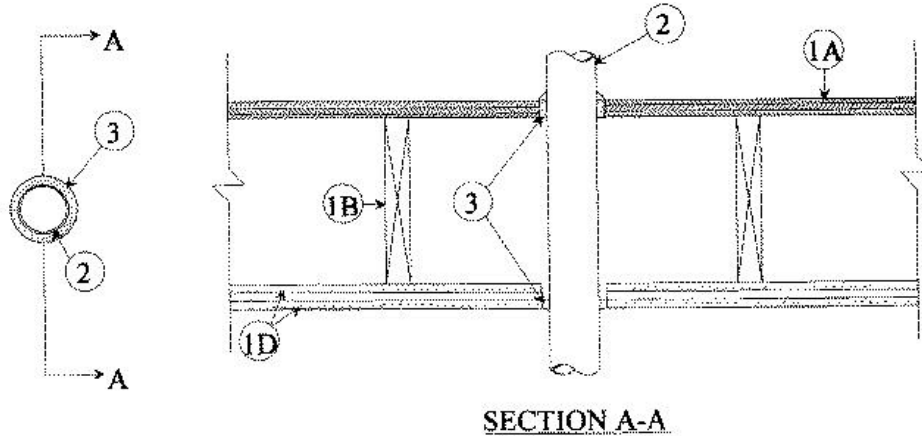

1. Floor Ceiling Assembly — The 1 hr fire-rated solid or trussed lumber joist floor-ceiling assembly shall be constructed of the materials and in the manner specified in the individual L500 Series Floor-Ceiling Designs in the UL Fire Resistance Directory. The 2 hr fire-rated wood joist floor-ceiling assembly shall be constructed of the materials and in the manner specified in Design No. L505, L511 or L536 in the UL Fire Resistance Directory. The general construction features of the floor-ceiling assembly are summarized below:

A. Flooring System — Lumber or plywood subfloor with finish floor of lumber, plywood or **Floor Topping Mixture*** as specified in the individual Floor-Ceiling Design. Max diam of floor opening is 5-1/2 in. (140 mm).

B. Wood Joists — For 1 hr fire-rated floor-ceiling assemblies nom 10 in. (254 mm) deep (or deeper) lumber, steel or combination lumber and steel joists, trusses or **Structural Wood Members*** with bridging as required and with ends firestopped. 2 by 10 in. (51 by 254 mm) lumber joists spaced 16 in. (406 mm) OC with nom 1 by 3 in. (25 by 76 mm) lumber bridging and with ends firestopped.

C. Furring Channels — (Not Shown) — In 2 hr fire-rated assemblies, resilient galv steel furring installed perpendicular to wood joists between first and second layers of wallboard (Item 1D) and spaced max 24 in. (610 mm) OC. In 1 hr fire-rated assemblies, resilient galv steel furring installed perpendicular to wood joists between gypsum board and wood joists as specified in the individual Floor-Ceiling Design. Furring channels spaced max 24 in. (610 mm) OC.

D. Gypsum Board* — Nom 4 ft (1.2 m) wide by 5/8 in. (16 mm) thick as specified in the individual Floor-Ceiling Design. First layer of gypsum board nailed to wood joists. Second layer of gypsum board (2 hr fire-rated assembly) screw-attached to furring channels. Max diam of ceiling opening is 5-1/2 in. (140 mm).

The F and FH Ratings of the firestop system are equal to the hourly fire rating of the floor-ceiling assembly in which it is installed.

1.1 Chase Wall — (Not Shown, Optional) The through penetrants (Item 2) may be routed through a 1 or 2 hr fire-rated single double or staggered wood stud/gypsum board chase wall having a fire rating consistent with that of the floor-ceiling assembly. The chase wall shall be constructed of the materials and in the manner specified in the individual U300 Series Wall and Partition Designs in the UL Fire Resistance Directory and shall include the following construction features:

A. Studs — Nom 2 by 6 in. (51 by 152 mm) lumber of double nom 2 by 4 in. (51 by 102 mm) lumber studs.

B. Sole Plate — Nom 2 by 6 in. (51 by 152 mm) lumber or parallel 2 by 4 in. (51 by 102 mm) lumber plates, tightly butted. Max diam of opening is 5-1/2 in. (140 mm).

C. Top Plate — The double top plate shall consist of two nom 2 by 4 in. (51 by 102 mm) lumber plates or two sets of nom 2 by 4 in. (51 by 102 mm) lumber plates tightly butted. Max diam of opening is 5-1/2 in. (140 mm).

D. Gypsum Board* — Thickness, type, number or layers and fasteners shall be as specified in individual Wall and Partition design.

2. **Through Penetrant** — One metallic pipe, conduit or tubing to be installed either concentrically or eccentrically within the firestop system. Pipe, conduit or tubing to be rigidly supported on both sides of floor-ceiling assembly. The following types and sizes of metallic pipes, conduits or tubing may be used:

A. **Steel Pipe** — Nom 4 in. (102 mm) diam (or smaller) Schedule 10 (or heavier) steel pipe.

B. **Conduit** — Nom 4 in. (102 mm) diam (or smaller) steel electrical metallic tubing or 4 in. (102 mm) diam galv steel conduit.

C. **Copper Tubing** — Nom 3 in (76 mm) diam (or smaller) Type L (or heavier) copper tubing.

D. **Copper Pipe** — Nom 3 in. (76 mm) diam (or smaller) Regular (or heavier) copper pipe.

The annular space within the firestop system is dependent upon the nom diam of the through penetrant. If the nom diam of the through penetrant is 3 in. (76 mm) or less, the annular space within the firestop system shall be a min 0 in. (point contact) to a max 5/8 in. (16 mm). If the nom diam of the through penetrant is greater than 3 in. (76 mm), the annular space within the firestop system shall be a nom 1/2 in. (13 mm).

3. **Fill, Void or Cavity Material* — Sealant** — Min 3/4 in. (19 mm) thickness of fill material applied within annulus on top surface of floor. Min 5/8 in. (16 mm) thickness of fill material applied within annulus on bottom surface of ceiling or bottom top plate. Additional fill material to be installed such that a min 1/4 in. (6 mm) crown is formed around the through penetrant on top surface of floor and bottom surface of ceiling or bottom top plate.

RECTORSEAL — FlameSafe FS1900, FS1901, FS1905, FS1929, [Metacaulk 1000](#), [Metacaulk 350i](#), Biostop 350i or Biostop 500+

*,+ Indicates such products shall bear the UL or cUL Certification Mark for jurisdictions employing the UL or cUL Certification (such as Canada), respectively.

Reprinted from the Online Certifications Directory with permission from UL. ©UL LLC