

ANSI/UL2079	CAN/ULC S115
Assembly Rating - 1 & 2 Hr (See Item 2)	F Rating - 1 & 2 Hr (See Item 2)
Nominal Joint Width - 3/4 In. (19mm) Max	FT Rating - 1 & 2 Hr (See Item 2)
L Rating At Ambient — Less Than 1 CFM/Lin ft	FH Rating - 1 & 2 Hr (See Item 2)
L Rating At 400°F — Less Than 1 CFM/Lin ft	FTH Rating - 1 & 2 Hr (See Item 2)
	Nominal Joint Width - 19 mm Max
	L Rating At Ambient — Less Than 1 CFM/Lin ft
	L Rating At 400°F — Less Than 1 CFM/Lin ft

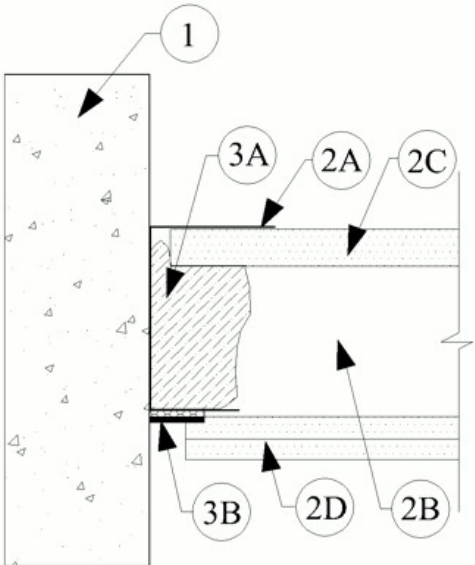

Configuration A

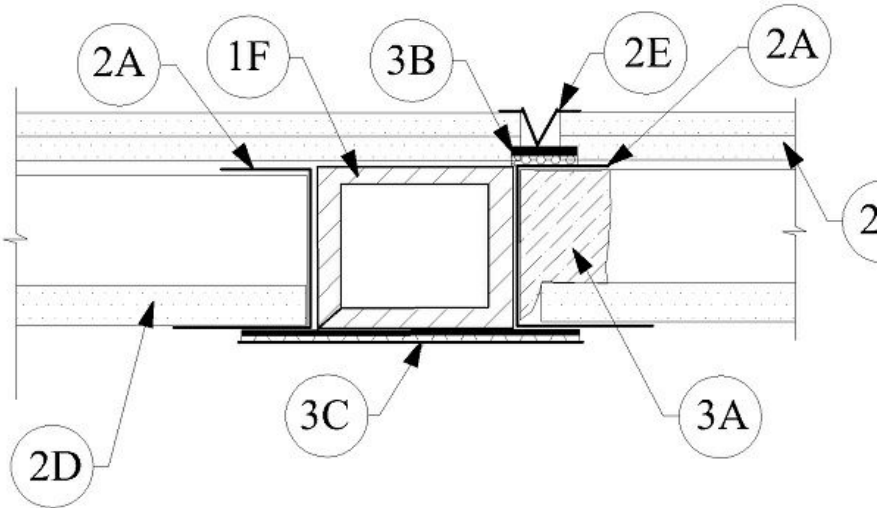

Configuration B

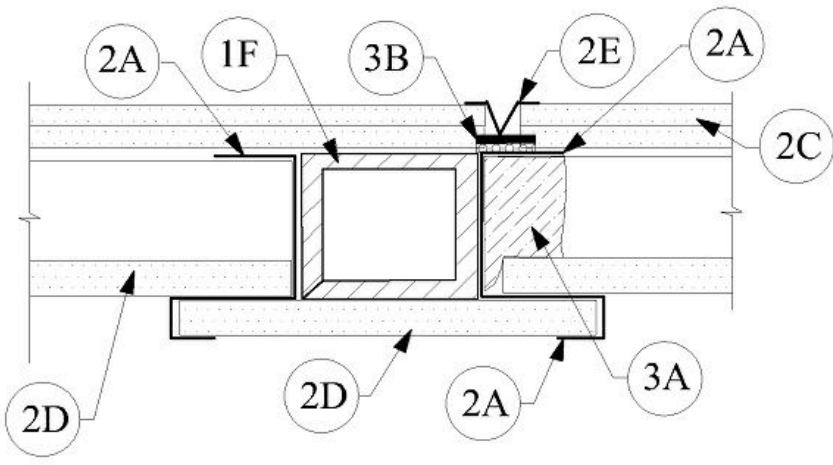

Configuration C

1. Concrete Wall Assembly — Min 4-1/2 in. (114 mm) thick reinforced lightweight or normal weight (100-150 pcf or 1600-2400 kg/m³)

structural concrete.

2. Shaft Wall Assembly — The 1 or 2 hr fire rated shaft wall assembly shall be constructed of the materials and in the manner described in the individual U400, V400 or W400 Series Wall and Partition Design in the UL Fire Resistance Directory and shall include the following construction features:

A. Steel Runners — "J"-shaped runner, min 2-1/2 in. (63 mm) wide with unequal legs of min 1-1/4 in. (32 mm) and 2-1/4 in. (57 mm), fabricated from min 0.029 20ga galv steel for use with fill, void, cavity material (Item 3B). Runners positioned with short leg toward finished side of wall. Runners attached to walls with steel fasteners spaced max 24 in. (610 mm) OC. As an alternate to the "J"-shaped floor runner, a min 2-1/2 in. (63 mm) wide by 1-1/4 in. (32 mm) deep channel formed from min 0.029 20ga galv steel may be used.

B. Steel Studs — "C-T", "I", or "C-H" shaped steel studs to be min 2-1/2 in. (63 mm) wide and formed of min 25 MSG galv steel. Studs spaced 24 in. (610 mm) OC. After installation of gypsum board liner panels (Item 2C), studs secured to flange of floor runner on finished side of wall only with typical steel fasteners.

C. Gypsum Board* — 1 in. (25 mm) thick by 24 in. (610 mm) wide gypsum board liner panels. Vertical edges inserted in "T" shaped section of "C-T" studs, into holding tabs of "I" studs or into "H" shaped section of "C-H" studs.

D. Gypsum Board* — Gypsum board sheets, 1/2 or 5/8 in. (13 or 16 mm) thick, applied on finished side of wall as specified in the individual U400, V400 or W400 Series Wall and Partition Design. A max 3/4 in. (19 mm) gap shall be maintained between the side of the gypsum board and face of concrete wall assembly.

E. Batts and Blankets* — (Not shown) Glass fiber or mineral wool batt insulation placed to fill stud cavity. Glass fiber insulation to have a min density of 0.9 pcf (14 kg/m³) and a min R-13 thermal insulation rating. Mineral wool batt insulation to have a min density of 3 pcf (48 kg/m³).

See Batts and Blankets (BKNV) Category in the Building Materials Directory and Batts and Blankets (BZJZ) Category in the Fire Resistance Directory for names of Classified Companies.

The hourly Assembly, F, FT, FT and FTH Ratings of the joint system are equal to the hourly rating of the wall.

F. Hollow Steel Shape HSS — (Configuration B and C) - Hollow Steel Shape Column located inside wall cavity. Tube not evaluated as a load-bearing member. Max 4 x 8 in. (102x203 mm)

Configuration A

3. Joint System — Max separation between side of gypsum board and face of concrete wall assembly is 3/4 in. (19 mm) at time of installation. The joint system consists of the following:

A. Forming Material* — Min 3 in. thickness of min 4 pcf (64 kg/m³) mineral wool batt insulation cut to width of track, compressed min 25 percent in width and friction fit into steel runner between leg of track and gypsum liner board.

See **Forming Material** (XH KU) category in the Fire Resistance Directory for names of manufacturers.

B. Fill, Void or Cavity Material* — For max 3/4 in. (19 mm) joint, a min 0.029 in. 20ga track (Item 2A or 2A1), with a min 1 in. (25 mm) wide composite thermal gasket applied to finished side of steel runner with outer edge of gasket in continuous firm contact with concrete wall assembly. Gypsum board to overlap a min of 1/4 in. (6 mm) over the gasket respectively.

SAFTI SEAL — FRG 75

C. Fill, Void or Cavity Material* — Sealant — (Optional) A bead or dab of sealant may be used to seal small gaps in substrate adjacent FRG to maintain L Rating.

UNITED STATES GYPSUM CO — Type AS

RECTORSEAL — [Smoke and Acoustic, Metacaulk 150+](#), 1000, 1200

Configuration B

2. Shaft Wall Assembly — The 1 or 2 hr fire rated gypsum board/stud wall assembly shall be constructed of the materials and in the manner described in the individual U400 or V400 Series Wall and Partition Design in the UL Fire Resistance Directory and shall include the following construction features:

A. Steel Floor and Ceiling Runners — Floor runners of wall assembly shall consist of min No. 20ga galv. steel channels to be provided with min 1-1/4 in. (32 mm) legs or J-shaped runner having min. one 1 in. (25mm) leg and one 2 in. (50mm) leg having a width to accommodate steel studs (Item 2D). Floor runners are secured with typical steel fasteners a max. 24 in. (610 mm) O/C.

B. Studs — "C-T", "I", or "C-H" shaped steel studs to be min 2-1/2 in. (63 mm) wide and formed of min 25ga galv steel. Studs cut 1 to 1-1/2 in. (38 to 51 mm) less in length than assembly height with bottom nesting in and secured to floor runner. Studs spaced max 24 in. (610 mm) OC.

C. Gypsum Board* — Gypsum board 1/2 or 5/8 in. (13 or 16 mm) thick, applied on finished side of wall as specified in the individual Wall and Partition Design. The boards extend across hollow steel shape.

D. Gypsum Board* — 1 in. (25 mm) thick by max 24 in. (610 mm) wide gypsum board liner panels. Panels installed max 1 in. (25 mm) away from vertical steel floor runners. Vertical edges inserted into "T" shaped section of "C-T" studs, into holding tabs of "I" studs or into "H"-shaped section of "C-H" studs.

E. Control Joint — (Optional) Vinyl or Zinc control joint conforming to ASTM C1047 attached to gypsum board on each side of opening.

F. Batts and Blankets* — (Not Shown) Glass fiber or mineral wool batt insulation placed to fill stud cavity. Glass fiber insulation to have a min density of 0.9 pcf (14 kg/m³) and a min R-13 thermal insulation rating. Mineral wool batt insulation to have a min density of 3 pcf (48 kg/m³).

See Batts and Blankets (BKNV) Category in the Building Materials Directory and Batts and Blankets (BZJZ) Category in the Fire Resistance Directory for names of Classified Companies.

The hourly fire rating of the joint system is equal to the hourly fire rating of the wall.

3. Joint System — Max separation between opposing gypsum at vertical joint (Item 2C finished side) at time of installation is 1/2 in. (13 mm). The joint system shall consist of the following:

A. Forming Material* — Min 4 in. (102 mm) thick min 4 pcf (64 kg/m³) mineral wool batt insulation cut 25% wider than width of the vertical floor runner and installed into runner between leg of track and gypsum liner board.

INDUSTRIAL INSULATION GROUP L L C — MinWool-1200 Safing

ROXUL INC — Safe

ROCK WOOL MANUFACTURING CO — Delta Board

THERMAFIBER INC — SAF

JOHNS MANVILLE — Safing

B. Fill, Void or Cavity Material* — For nom 1/2 in. (12 mm) joints a min. 1-1/4 in. (32 mm) wide composite thermal gasket applied to finished side of vertical floor runner. Gypsum board to overlap a min of 1/4 in. (6 mm) over the gasket respectively.

SAFTI SEAL — FRG-100

C. Fill, Void or Cavity Material* - Min 20ga steel plate with composite thermal gasket applied to one side and facing wall assembly overlapping opposing vertical floor runners by min. 1 in (13 mm) on each runner and attached with typical steel fasters a max 8 in O/C (203 mm) O/C.

SAFTI-SEAL – SPG

D. Fill, Void or Cavity Material* Sealant — (Optional) — A bead of sealant may be used to seal small voids around SPG maintain L Ratings. Any Fill, Void or Cavity Materials* sealant may be used.

UNITED STATES GYPSUM CO — Type AS

RECTORSEAL — [Metacaulk 150+](#), 1000, 1200

Configuration C

2. Shaft Wall Assembly — The 1 or 2 hr fire rated gypsum board/stud wall assembly shall be constructed of the materials and in the manner described in the individual U400 or V400 Series Wall and Partition Design in the UL Fire Resistance Directory and shall include the following construction features:

A. Steel Vertical Runners — Vertical runners of wall assembly shall consist of min No. 20ga galv. steel J-Shaped Runner with one 2 in. (50 mm) and one 3in. (76 mm) solid leg with a width to accommodate steel studs (Item 2B) and include J Retaining flanges formed off 3 in. (76 mm) legs.

B. Studs — "C-T", "I", or "C-H" shaped steel studs to be min 2-1/2 in. (63 mm) wide and formed of min 25ga galv steel. Studs cut 1 to 1-1/2 in. (38 to 51 mm) less in length than assembly height with bottom nesting in and secured to floor runner. Studs spaced max 24 in. (610 mm) OC.

C. Gypsum Board* — Gypsum board 1/2 or 5/8 in. (13 or 16 mm) thick, applied on finished side of wall as specified in the individual Wall and Partition Design. The boards extend across hollow steel shape.

D. Gypsum Board* — 1 in. (25 mm) thick by max 24 in. (610 mm) wide gypsum board liner panels. Panels installed max 1 in. (25 mm) away from vertical steel floor runners. Vertical edges inserted into "T" shaped section of "C-T" studs, into holding tabs of "I" studs or into "H"-shaped section of "C-H" studs. Nom. 1 in (25 mm) thick gypsum board liner panels cut to length max 24 in. (600 mm) and inserted into and between J Retaining Flanges of opposing Vertical Runners.

E. Control Joint — (Optional) Vinyl or Zinc control joint conforming to ASTM C1047 attached to gypsum board on each side of opening.

F. Batts and Blankets* — (Not Shown) Glass fiber or mineral wool batt insulation placed to fill stud cavity. Glass fiber insulation to have a min density of 0.9 pcf (14 kg/m³) and a min R-13 thermal insulation rating. Mineral wool batt insulation to have a min density of 3 pcf (48 kg/m³).

See Batts and Blankets (BKNV) Category in the Building Materials Directory and Batts and Blankets (BZJZ) Category in the Fire Resistance Directory for names of Classified Companies.

The hourly fire rating of the joint system is equal to the hourly fire rating of the wall.

3. Joint System — Max separation between opposing gypsum at vertical joint (Item 2C, finished side) at time of installation is 1/2 in. (13 mm). The joint system shall consist of the following:

A. Forming Material* — Min 4 in. (102 mm) thick min 4 pcf (64 kg/m³) mineral wool batt insulation cut 25% wider than width of the vertical floor runner and installed into runner between leg of track and gypsum liner board.

INDUSTRIAL INSULATION GROUP L L C — MinWool-1200 Safing

ROCK WOOL MANUFACTURING CO — Delta Board

THERMAFIBER INC — SAF

JOHNS MANVILLE — Safing

B. Fill, Void or Cavity Material* — For nom 1/2 in. (12 mm) joints a min. 1-1/4 in. (32 mm) wide composite thermal gasket applied to finished side of vertical floor runner. Gypsum board to overlap a min of 1/4 in. (6 mm) over the gasket respectively.

SAFTI SEAL — FRG-100

D. Fill, Void or Cavity Material* Sealant — (Optional) — A bead of sealant may be used to seal small voids around attachment plate to maintain L Ratings. Any Fill, Void or Cavity Materials* sealant may be used.

UNITED STATES GYPSUM CO — Type AS

RECTORSEAL — [Metacaulk 150+](#), 1000, 1200

* Indicates such products shall bear the UL or cUL Certification Mark for jurisdictions employing the UL or cUL Certification



(such as Canada), respectively.