

Design/System/Construction/Assembly Usage Disclaimer

- Authorities Having Jurisdiction should be consulted in all cases as to the particular requirements covering the installation and use of UL Certified products, equipment, system, devices, and materials.
- Authorities Having Jurisdiction should be consulted before construction.
- Fire resistance assemblies and products are developed by the design submitter and have been investigated by UL for compliance with applicable requirements. The published information cannot always address every construction nuance encountered in the field.
- When field issues arise, it is recommended the first contact for assistance be the technical service staff provided by the product manufacturer noted for the design. Users of fire resistance assemblies are advised to consult the general Guide Information for each product category and each group of assemblies. The Guide Information includes specifics concerning alternate materials and alternate methods of construction.
- Only products which bear UL's Mark are considered Certified.

BXUV - Fire Resistance Ratings - ANSI/UL 263 Certified for United States
 BXUV7 - Fire Resistance Ratings - CAN/ULC-S101 Certified for Canada

See General Information for Fire-resistance Ratings - ANSI/UL 263 Certified for United States Design Criteria and Allowable Variances

See General Information for Fire Resistance Ratings - CAN/ULC-S101 Certified for Canada Design Criteria and Allowable Variances

Design No. N782

May 08, 2024

Restrained Beam Ratings — 1, 1-1/2, 2, 3 and 4 Hr
Unrestrained Beam Ratings — 1, 1-1/2, 2, 3 and 4 Hr

This design was evaluated using a load design method other than the Limit States Design Method (e.g., Working Stress Design Method). For jurisdictions employing the Limit States Design Method, such as Canada, a load restriction factor shall be used — See Guide **BXUV** or **BXUV7**

* Indicates such products shall bear the UL or cUL Certification Mark for jurisdictions employing the UL or cUL Certification (such as Canada), respectively.

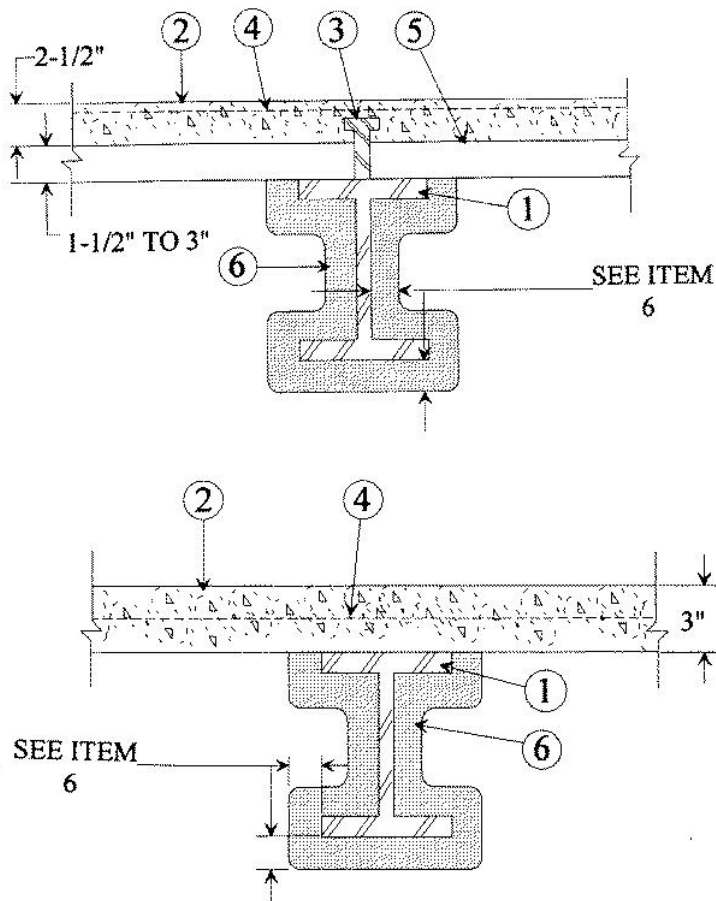

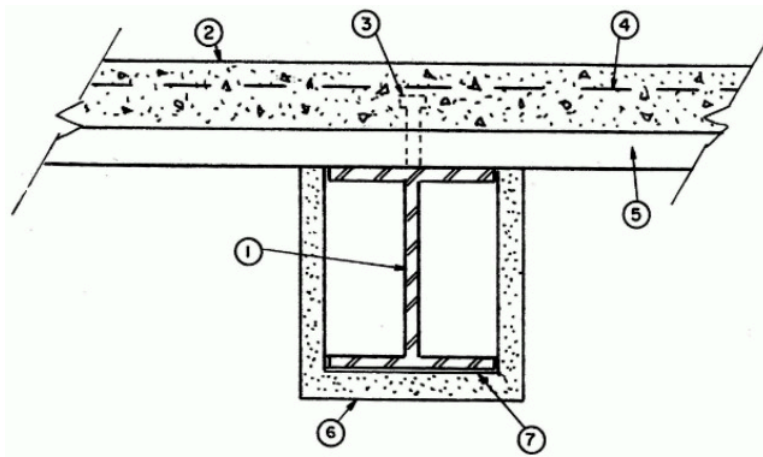

- 1. **Steel Beam** — W8x28 min size.
- 2. **Normal Weight or Lightweight Concrete** — Compressive strength, 3000 psi. For normal weight concrete either carbonate or siliceous aggregate may be used. Unit weight, 148 pcf. For lightweight concrete unit weight 110 pcf.
- 3. **Shear Connector** — (Optional) — Studs, 3/4 in. diam headed type or equivalent per AISC specifications. Welded to the top flange of beam through the steel floor units.
- 4. **Welded Wire Fabric** — (Optional) — 6x6-10/10 SWG.
- 5. **Steel Floor and Form Units** — 1-1/2 to 3 in. deep fluted units welded to beam.

6. **Spray-Applied Fire Resistive Materials*** — Applied by mixing with water and spraying in more than one coat to the beam to the final thicknesses shown below. When fluted or corrugated steel floor units are used, crest areas shall be filled with Spray-Applied Fire Resistive Materials above the beam. Beam surfaces must be clean and free of dirt, loose scale and oil. Min average and min ind. density of 15/14 pcf respectively. Min avg and min ind density of 22/19 pcf respectively for Types Z-106, Z-106/HY, Z-106/G. Min avg and min ind density of 40/36 pcf respectively for Types AV650, Z-146, Z-146PC and Z-146T cementitious mixture. Min avg and min ind density of 50/45 pcf respectively for Types AV800, Z-156, Z-156T and Z-156PC. For method of density determination, see Design Information Section. The thicknesses of Spray-Applied Fire Resistive Materials shown in the table below are applicable when the beams are supporting solid concrete slabs or floor assemblies containing only fluted floor or form units with lightweight concrete.

Rating Hr	Min Thkns In.	
	Restrained Beam	Unrestrained Beam
1	5/16	5/16
1-1/2	7/16	5/8
2	11/16	7/8
3	1-3/16	1-5/16
4	1-5/8	1-5/8

The thickness of Spray-Applied Fire Resistive Materials shown in the table below are only applicable when the beams are supporting solid, normal weight, concrete slabs or floor assemblies containing only fluted floor or form units, topped with normal weight concrete.

Rating Hr	Min Thkns In.	
	Restrained Beam	Unrestrained Beam
1	5/16	5/16
1-1/2	3/8	5/8
2	9/16	7/8
3	1	1-5/16
4	1-7/16	1-5/8

The thickness of Spray-Applied Fire Resistive Materials shown in the table below are applicable when the thickness applied to the beams' lower flange edges is reduced by one-half and the beams are supporting solid concrete slabs or floor assemblies containing only fluted floor or form units with lightweight concrete.

Rating Hr	Min Thkns In.	
	Restrained Beam	Unrestrained Beam
1	7/16+	7/16+
1-1/2	7/16+	3/4
2	11/16	1
3	1-3/16	1-7/16
4	1-11/16	1-15/16

+ Thickness applied to beams' lower flange edges shall be a min of 1/4 in.

The thickness of Spray-Applied Fire Resistive Materials shown in the table below are applicable when the thickness applied to the beams' lower flange edges is reduced by one-half and the beams are supporting solid concrete slabs or floor assemblies containing only fluted floor or form units with normal weight concrete.

Rating Hr	Min Thkns In.	
	Restrained Beam	Unrestrained Beam
1	3/8	3/8
1-1/2	3/8	5/8
2	9/16	7/8
3	1	1-7/16
4	1-7/16	1-15/16

ARABIAN VERMICULITE INDUSTRIES — Types MK-6/HY, MK-6/HY Extended Set, MK-10 HB, MK-10 HB Extended Set, MK-6/HB, MK-6s, MK-6 GF, MK-6 GF Extended Set, MK-1000/HB, MK-1000/HB Extended Set, Z-106, Z-106/G, Z-106/HY, Z-146 investigated for exterior use. Types AV650 and AV800 investigated for external use.

GCP KOREA INC — Types MK-6/HY, MK-6/HY Extended Set, MK-10 HB, MK-10 HB Extended Set, MK-6/HB, MK-6s, MK-6 GF, MK-6 GF Extended Set, MK-1000/HB, MK-1000/HB Extended Set, Z-106, Z-106/G, Z-106/HY, Z-146 investigated for exterior use.

GCP APPLIED TECHNOLOGIES INC — Types MK-6/HY, MK-6/HY Extended Set, MK-10 HB, MK-10 HB Extended Set, MK-6/HB, MK-6s, MK-6 GF, MK-6 GF Extended Set, MK-1000/HB, MK-1000/HB Extended Set, RG, Z-106, Z-106/G, Z-106/HY, Z-146, Z-146T, Z146PC, Z-156, Z-156T and Z-156PC investigated for exterior use.

6A. Spray-Applied Fire Resistive Materials* — Applied by mixing with water and spraying in more than one coat to the beam to the final thicknesses shown below. When fluted steel floor units are used, crest areas shall be filled with Spray-Applied Fire Resistive Materials above the beam. Beam surfaces must be clean and free of dirt, loose scale and oil. Min average and min ind. density of 22/20 pcf respectively. For method of density determination, see Design Information Section.

The thicknesses of Spray-Applied Fire Resistive Materials shown in the table below are applicable when the beams are supporting solid concrete slabs or floor assemblies containing only fluted floor or form units with lightweight concrete.

Rating Hr	Min Thkns In.	
	Restrained Beam	Unrestrained Beam
1	5/16	5/16
1-1/2	7/16	9/16
2	5/8	13/16
3	1-1/16	1-1/4
4	1-5/8	1-5/8

The thicknesses of Spray-Applied Fire Resistive Materials shown in the table below are applicable when the beams are supporting solid concrete slabs or floor assemblies containing only fluted floor or form units with normal weight concrete.

Rating Hr	Min Thkns In.	
	Restrained Beam	Unrestrained Beam
1	5/16	5/16
1-1/2	3/8	9/16
2	9/16	13/16
3	1	1-1/4
4	1-7/16	1-5/8

The thickness of Spray-Applied Fire Resistive Materials shown in the table below are applicable when the thickness applied to the beams' lower flange edges is reduced by one-half and the beams are supporting solid concrete slabs or floor assemblies containing only fluted floor or form units with lightweight or normal weight concrete.

Rating Hr	Min Thkns In.	
	Restrained Beam	Unrestrained Beam
1	7/16+	7/16+
1-1/2	7/16+	11/16
2	11/16	15/16
3	1-3/16	1-3/8
4	1-11/16	1-15/16

+ Thickness applied to beams' lower flange edges shall be a min of 1/4 in.

The thickness of Spray-Applied Fire Resistive Materials shown in the table below are applicable when the thickness applied to the beams' lower flange edges is reduced by one-half and the beams are supporting solid concrete slabs or floor assemblies containing only fluted floor or form units with normal weight concrete.

Rating Hr	Min Thkns In.	
	Restrained Beam	Unrestrained Beam
1	3/8	3/8
1-1/2	3/8	5/8
2	9/16	7/8
3	1	1-7/16
4	1-7/16	1-15/16

ARABIAN VERMICULITE INDUSTRIES — Type Z-106/HY

GCP KOREA INC — Type Z-106/HY

GCP APPLIED TECHNOLOGIES INC — Z-106/HY

7. Metal Lath — (Optional for contour applications, required for boxed applications) - 3.4 lb/sq yd expanded steel. May be tied to lath hangers with No. 18 SWG steel wire spaced 6 in. OC max. or fastened directly to the steel with welds, screws, or powder actuated fasteners

8. Lath Hangers — (To be used with Item 7) — No. 6 SWG steel wire, spaced 27 in. OC max.

* Indicates such products shall bear the UL or cUL Certification Mark for jurisdictions employing the UL or cUL Certification (such as Canada), respectively.

Last Updated on 2024-05-08

The appearance of a company's name or product in this database does not in itself assure that products so identified have been manufactured under UL Solutions' Follow - Up Service. Only those products bearing the UL Mark should be considered to be Certified and covered under UL Solutions' Follow - Up Service. Always look for the Mark on the product.

UL Solutions permits the reproduction of the material contained in Product iQ subject to the following conditions: 1. The Guide Information, Assemblies, Constructions, Designs, Systems, and/or Certifications (files) must be presented in their entirety and in a non-misleading manner, without any manipulation of the data (or drawings). 2. The statement "Reprinted from Product iQ with permission from UL Solutions" must appear adjacent to the extracted material. In addition, the reprinted material must include a copyright notice in the following format: "©2024 UL LLC."