

F Rating — 2 Hr  
T Rating — 2 Hr

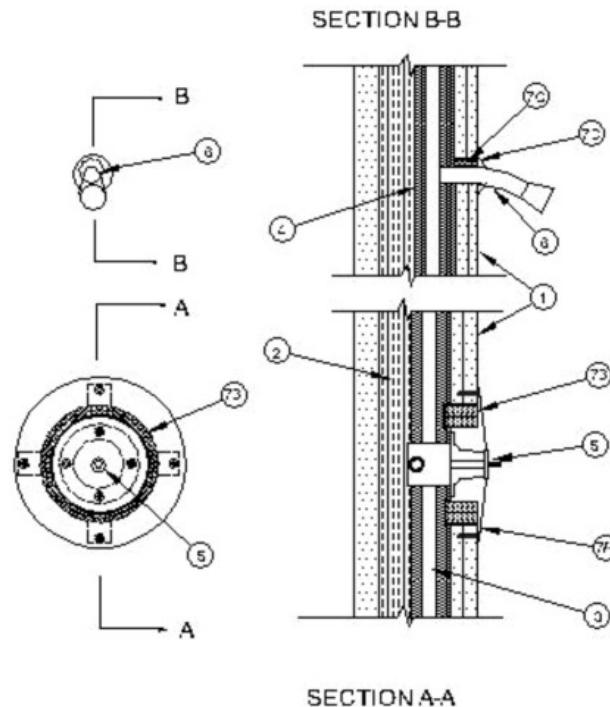

1. **Wall Assembly** — The 2 hr fire-rated gypsum board/stud shaft wall assembly shall be constructed of the materials and in the manner specified in the individual U400 or V400 Series Wall and Partition Designs in the UL Fire Resistance Directory and shall incorporate the following construction features:

A. **Steel Studs** — "C-H", "C-T" or "I" shaped studs, min 2-1/2 in. (64 mm) wide by 1-1/2 in. (32 mm) deep, fabricated from min No. 25 gauge galv steel, spaced max 24 in. (610 mm). OC.

B. **Gypsum Board\*** — 1 in. (25 mm) thick, 24 in. (610 mm) wide gypsum liner panels installed vertically.

C. **Gypsum Board\*** — Min 5/8 in. (13 or 16 mm) thick gypsum boards. The gypsum board type, thickness, number of layers, fastener type and sheet orientation shall be as specified in the individual Wall and Partition Design. Max diam of opening for the shower valve (Item 5) is 4-3/8 in. (111 mm). Max diam of opening for the shower pipe (Item 6) is 1 in. (25 mm).

2. **Insulation\*** — Each stud cavity shall be fully insulated with nom 2 in. thick, min 4 pcf (64 kg/m<sup>3</sup>) mineral wool batt insulation.

3. **Internal Plumbing** — Hot and cold water lines are installed within the stud cavity, routed for connection to shower valves and piping (Items 5 and 6) installed on finished side of wall assembly. The plumbing is to consist of nom 1-1/4 in. (32 mm) diam (or smaller) Type L (or heavier) copper tubing or Regular (or heavier) copper pipe.

4. **Tube Insulation — Plastics+** — Nom 1 in. (25 mm) thick acrylonitrile butadiene/polyvinyl chloride (AB/PVC) flexible foam furnished in the form of tubing or sheets. All seams are to be tightly butted and secured by means of tie wires, tape or an equivalent means.

See **Plastics+** (QMFZ2) category in the Plastics Component Directory for names of manufacturers. Any Recognized Component tube insulation material meeting the above specifications and having a UL94 Flammability Classification of 94-5VA may be used.

5. **Shower Valve** — Brass shower valve, nom 3-1/4 in. (83 mm) diam installed within opening on finished side of wall assembly. The annular space between the valve body and the periphery of opening shall be min 1/2 in. (13 mm) to max 1 in. (25 mm). Shower valve provided with a steel escutcheon plate installed after the installation of the firestop system (Item 7) and sized to completely cover the opening.

6. **Shower Pipe** — Nom 1/2 in. (13 mm) diam steel tubing, routed through opening on finished side of wall assembly. The annular space between the tubing and the periphery of opening shall be min 0 in. (point contact) to max 1/2 in. (13 mm). Shower pipe provided with a steel escutcheon plate installed after the installation of the firestop system (Item 7) and sized to completely cover the opening.

7. **Firestop System** — The firestop system shall consist of the following:

A. **Steel Collar** — Collar fabricated from coils of precut min 0.016 in. (0.41 mm) thick (No. 28 gauge) galv steel available from fill material manufacturer. Collar shall be nom 2 in. (51 mm) deep with 1 in. (25 mm) wide by 1-1/2 in. (38 mm) long anchor tabs on 4 in. (102 mm) centers for securement to surfaces of wall. In addition, collars contain retainer tabs 1/2 in. (13 mm) wide by 3/4 in. (19 mm) long, located opposite the anchor tabs. Retainer tabs to be cut to 1/2 in. (13 mm) in length and folded 90 deg inward toward the shower valve. Collar shall be wrapped around the periphery of opening, overlapping min 1 in. (25 mm) and inverted into the opening around the shower valve. The anchor tabs are folded 90 deg away from the valve and secured to wall surface at each anchor tab by means of min 1/8 in. (3.2 mm) diam by 2-1/4 in. (57 mm) long hollow wall anchors in conjunction with 1/2 in. (13 mm) diam steel washers.

B. **Fill, Void or Cavity Materials\* - Wrap Strip** — Nom 2 in. (51 mm) wide by nom 1/4 in. (6 mm) thick intumescent wrap strip. Two layers shall be installed into the collar such that the layers tightly fitted to the inside of the steel collar. Wrap strip layers are held in position using tape.

**RECTORSEAL** — [Metacaulk Wrap Strip](#)

C. **Packing Material** — Min 1 in. (25 mm) thickness of min 4.0 pcf (64 kg/m<sup>3</sup>) mineral wool batt insulation firmly packed into opening as a permanent form. Packing material to be recessed from surface of wall to accommodate the required thickness of fill material.

D. **Fill, Void or Cavity Materials\* - Caulk** — Min 1/4 in. (6 mm) thickness of caulk applied within annulus around the shower pipe, flush with surface of wall assembly. An additional film of caulk (not shown) may or may not be applied over the exposed edges of the wrap strip.

**RECTORSEAL** — [Metacaulk 835+](#)

+Bearing the UL Recognized Marking

\*,+ Indicates such products shall bear the UL or cUL Certification Mark for jurisdictions employing the UL or cUL Certification (such as Canada), respectively.

Reprinted from the Online Certifications Directory with permission from UL. ©UL LLC