

ANSI/UL1479 (ASTM E814)	CAN/ULC S115
F Ratings - 1 and 2 Hr (See Item 1)	F Ratings - 1 and 2 Hr (See Item 1)
T Rating - 0 Hr	FT Rating - 0 Hr
L Rating At Ambient - 1.7 CFM/sq ft	FH Ratings - 1 and 2 Hr (See Item 1)
L Rating At 400 F - Less Than 1 CFM/sq ft	FTH Rating - 0 Hr
	L Rating At Ambient - 1.7 CFM/sq ft
	L Rating At 400 F - Less Than 1 CFM/sq ft

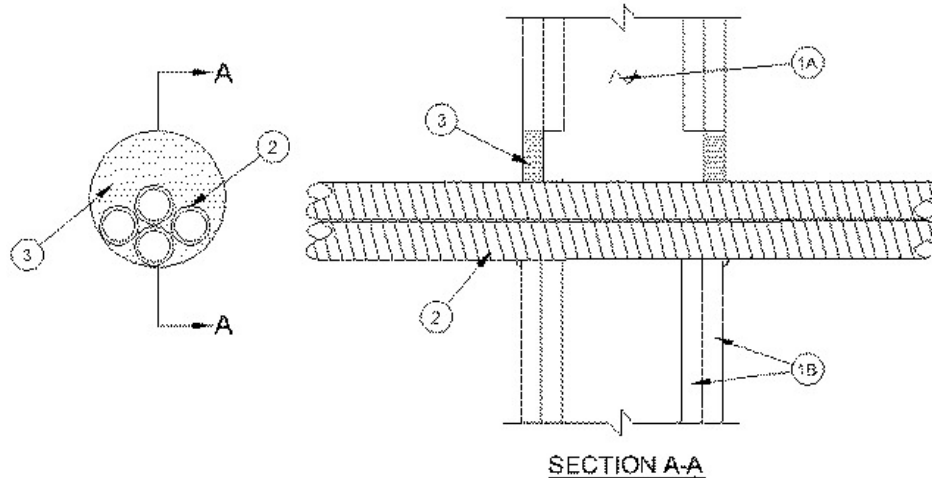

**1. Wall Assembly** — The 1 or 2 hr fire-rated gypsum board/stud wall assembly shall be constructed of the materials and in the manner described in the individual U300, U400 or V400 Series Wall and Partition Design in the UL Fire Resistance Directory and shall include the following construction features:

**A. Studs** — Wall framing may consist of either wood studs or steel channel studs. Wood studs to consist of nom 2 by 4 in. (51 by 102 mm) lumber spaced 16 in. (406 mm) OC. Steel studs to be min 3-5/8 in. (92 mm) wide and spaced max 24 in. (406 mm) OC.

**B. Gypsum Board\*** — 5/8 in. (16 mm) thick, 4 ft (1.2 m) wide with square or tapered edges. The gypsum board type, thickness, number of layers, fastener type and sheet orientation shall be as specified in the individual U300, U400 or V400 Series Design in the UL Fire Resistance Directory. Max diam of opening is 6 in. (152 mm).

**The hourly F Rating of the firestop system is equal to the hourly fire rating of the wall assembly in which it is installed.**

**2. Through Penetrants** — One or more nom 1-1/2 in. (38 mm) diam (or smaller) flexible steel conduits bundled together and installed within the opening. Max diam of through penetrant bundle shall be 4 in. (102 mm). The space between the through penetrants shall be a min of 0 in. (point contact) to a max of 2 in. (51 mm). The annular space between the through penetrants and periphery of opening shall be min 0 in. (point contact) to max 2 in. (51 mm). Conduit to be rigidly supported on both sides of wall assembly.

See **Flexible Metal Conduit (DXUZ)** category in the Electrical Construction Materials Directory for names of manufacturers.

**3. Fill, Void or Cavity Material\* — Sealant** — Min 5/8 in. (16 mm) thickness of fill material applied within annulus, flush with both surfaces of wall. At the point contact location between through penetrants and gypsum board, a min 3/8 in. (10 mm) diam bead of fill material shall be applied at the gypsum board/through penetrant interface on both surfaces of wall. Additional sealant shall be forced into interstices of through penetrants to max extent possible.

**RECTORSEAL** — FS 900+ Sealant, [Metacaulk MC 150+](#), Biostop BF.150+

\*,+ Indicates such products shall bear the UL or cUL Certification Mark for jurisdictions employing the UL or cUL Certification (such as Canada), respectively.