

ANSI/UL1479 (ASTM E814)	CAN/ULC S115
F Rating — 2 Hr	F Rating — 2 Hr
T Rating — 0 Hr	FT Rating — 0 Hr
	FH Rating — 2 Hr
	FTH Rating — 0 Hr

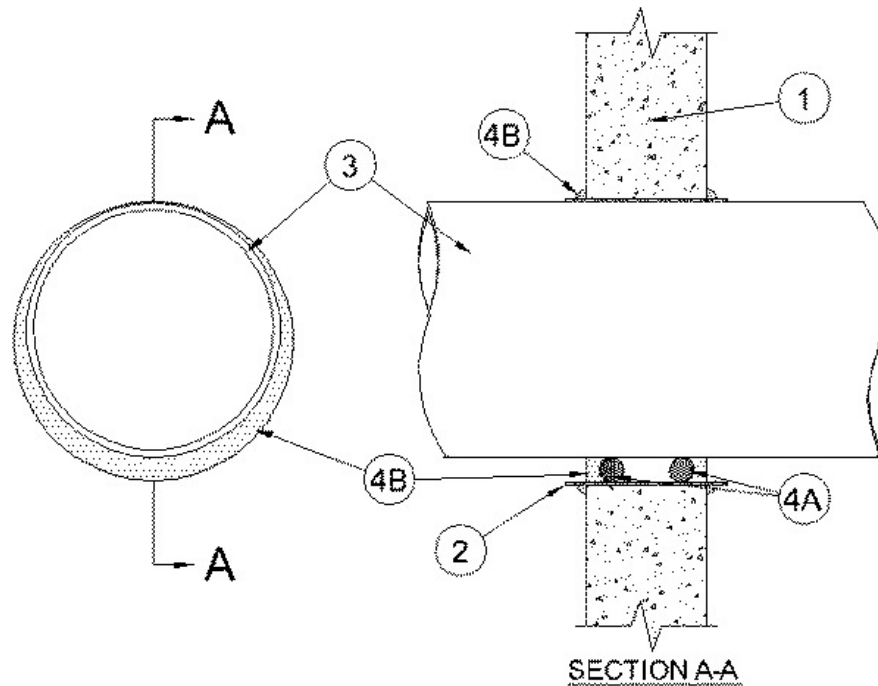

1. Wall Assembly — Min 6 in. (152 mm) thick reinforced lightweight or normal weight (100-150 pcf or 1600-2400 kg/m³) concrete. Wall may also be constructed of any UL Classified **Concrete Blocks***. Max diam of opening is 14-1/2 in. (368 mm).
See **Concrete Blocks** (CAZT) category in the Fire Resistance Directory for names of manufacturers.

2. Steel Sleeve — (Optional) — Max 14-1/2 in. (368 mm) diam sleeve fabricated from min 0.018 in. (0.46 mm) thick (28 gauge) galv sheet steel and having a min 1 in. (25 mm) lap along the longitudinal seam. Sheet steel coiled to a diam less than circular cutouts in wall assembly, inserted opening and allowed to uncoil against the circular cutouts. Sleeve to be installed flush with or extending max 1 in. (25 mm) beyond each surface of the wall assembly.

2A. Steel Sleeve — As an alternate to Item 2, max 12 in. (305 mm) Schedule 5 (or heavier) steel pipe, max 6 in. (152 mm) diam rigid steel conduit or max 4 in. (102 mm) EMT, cast or grouted into floor or wall assembly, flush with or extending a max 4 in. (102 mm) beyond each surface of the floor or wall assembly.

3. Through Penetrants — One metallic pipe, conduit or tubing to be installed concentrically or eccentrically within the firestop system. Pipe, conduit or tubing to be rigidly supported on both sides of wall assembly. The following types and sizes of metallic pipes, conduit or tubing may be used:

A. Steel Pipe — Nom 12 in. (305 mm.) diam (or smaller) Schedule 10 (or heavier) steel pipe. An annular space of min 0 in. (point contact) to max 1-3/4 in. (44 mm) is required within the firestop system.

B. Iron Pipe — Nom 12 in. (305 mm) diam (or smaller) Schedule 10 (or heavier) cast iron pipe. An annular space of min 0 in. (point contact) to max 1-3/4 in. (48 mm) is required within the firestop system.

C. Copper Tubing — Nom 4 in. (102 mm) diam (or smaller) Type L (or heavier) copper tube. An annular space of min 0 in. (point contact) to max 1-7/8 in. (48 mm) is required within the firestop system.

D. Copper Pipe — Nom 4 in. (102 mm) diam (or smaller) Regular (or heavier) copper pipe. An annular space of min 0 in. (point contact) to max 1-7/8 in. (48 mm) is required within the firestop system.

E. Conduit — Nom 6 in. (152 mm) diam (or smaller) steel conduit or or nom 4 in. diam (or smaller) steel electrical metallic conduit. An annular space of min 0 in. (point contact) to max 1-7/8 in. (48 mm) is required within the firestop system.

4. **Firestop System** — The firestop system shall consist of the following:

A. **Packing Material** — Foam backer rod firmly packed into opening as a permanent form. Packing material to be recessed from each surface of the wall to accommodate the required thickness of fill material.

B. **Fill Void or Cavity Materials* - Caulk** — Min 1/2 in. (13 mm) thickness of fill material applied within the annulus on both surfaces of the wall assembly. When steel sleeve is not used or when steel sleeve is flush with the wall surfaces, a min 1/2 in. (13 mm) diam bead of caulk shall be applied to the penetrant /concrete interface at the point contact location on both sides of wall. When steel sleeve is used, a bead of caulk is applied to the steel sleeve/concrete interface on both sides of wall. When sheet metal sleeve (Item 2) is used, fill material to be installed flush with both surfaces of wall within the sleeve. When rigid steel sleeve (Item 2A) is used, fill material may be installed flush with both ends of sleeve in walls.

RECTORSEAL — [MC 150+ Caulk](#), [Metacaulk 1000](#)

*,+ Indicates such products shall bear the UL or cUL Certification Mark for jurisdictions employing the UL or cUL Certification (such as Canada), respectively.

Reprinted from the Online Certifications Directory with permission from UL. ©UL LLC