

F Rating — 2 Hr
T Rating — 3/4 Hr

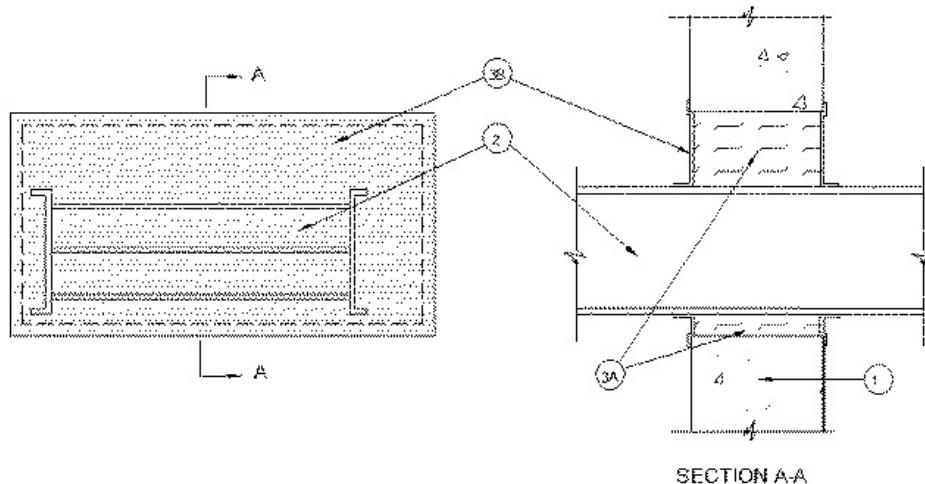

1. **Wall Assembly** — Min 6 in. thick reinforced lightweight or normal weight (100-150 pcf) concrete. Wall may also be constructed of any UL Classified **Concrete Blocks***. Max area of opening is 420 sq in. with max dimensions of 30 in.

See **Concrete Blocks** (CAZT) category in the Fire Resistance Directory for names of manufacturers.

2. **Busway+** — Nom 27 in. wide by 6 in. deep (or smaller) "I" shaped steel enclosure containing factory mounted copper or aluminum bars rated for 600 V, 4000A. One busway to be installed within the opening. The annular space between the tip of the busway and the periphery of the opening shall be min 3/4 in. to max 5 in. Busway to be rigidly supported on both sides of floor and wall assembly. The busway shall bear the UL Listing Mark and shall be installed in accordance with all provisions of Article 364 of the National Electrical Code, NFPA 70.

3. **Firestop System** — The firestop system shall consist of the following:

A. **Packing Material** — Min 5-3/4 thickness of min 4 pcf mineral wool batt insulation packed at 50 percent compression into opening as a permanent form. Packing material to be recessed from both surfaces of wall as required to accommodate the required thickness of fill material.

B. **Fill, Void or Cavity Materials* - Caulk** — Min 1/8 in. thickness of fill material applied within the annular space, flush with both surfaces of wall and overlapping min 1/2 in. onto each wall surface.

RECTORSEAL — [Metacaulk 1000](#)

*,+ Indicates such products shall bear the UL or cUL Certification Mark for jurisdictions employing the UL or cUL Certification (such as Canada), respectively.

Reprinted from the Online Certifications Directory with permission from UL. ©UL LLC