



BXUV.P714

Design/System/Construction/Assembly Usage Disclaimer

- Authorities Having Jurisdiction should be consulted in all cases as to the particular requirements covering the installation and use of UL Certified products, equipment, system, devices, and materials.
- Authorities Having Jurisdiction should be consulted before construction.
- Fire resistance assemblies and products are developed by the design submitter and have been investigated by UL for compliance with applicable requirements. The published information cannot always address every construction nuance encountered in the field.
- When field issues arise, it is recommended the first contact for assistance be the technical service staff provided by the product manufacturer noted for the design. Users of fire resistance assemblies are advised to consult the general Guide Information for each product category and each group of assemblies. The Guide Information includes specifics concerning alternate materials and alternate methods of construction.
- Only products which bear UL's Mark are considered Certified.

BXUV - Fire Resistance Ratings - ANSI/UL 263 Certified for United States

BXUV7 - Fire Resistance Ratings - CAN/ULC-S101 Certified for Canada

See General Information for Fire-resistance Ratings - ANSI/UL 263 Certified for United States Design Criteria and Allowable Variances

See General Information for Fire Resistance Ratings - CAN/ULC-S101 Certified for Canada Design Criteria and Allowable Variances

Design No. P714

March 11, 2020

Restrained Assembly Ratings - 1, 1-1/2 and 2 Hr.

Unrestrained Assembly Ratings - 1, 1-1/2 and 2 Hr.

Unrestrained Beam Ratings - 1, 1-1/2 and 2 Hr.

This design was evaluated using a load design method other than the Limit States Design Method (e.g., Working Stress Design Method). For jurisdictions employing the Limit States Design Method, such as Canada, a load restriction factor shall be used — See Guide BXUV or BXUV7

*** Indicates such products shall bear the UL or cUL Certification Mark for jurisdictions employing the UL or cUL Certification (such as Canada), respectively.**

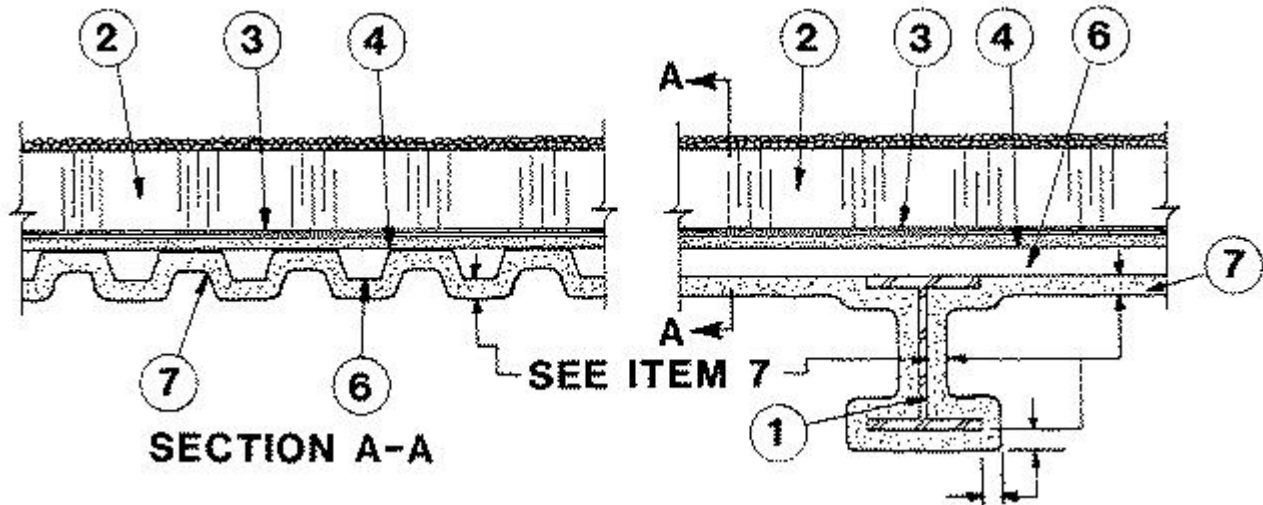

1. **Steel Beam** — W6x16, min size.

2. **Foamed Plastic*** — Rigid foamed plastic insulation, extruded polystyrene 2 by 4 ft boards, 1 to 8 in. thick. May be bonded to the membrane or installed without adhesion after final asphalt glaze coat has cooled. When applying more than one layer, successive layers shall be installed over preceding layer without attachment. The boards shall be covered with crushed stone or concrete pavers, at a rate of 10 psf, min.

OWENS CORNING SCIENCE AND TECHNOLOGY, LLC

THE DOW CHEMICAL CO — Type Styrofoam

T CLEAR CORP — 4-3/8 in. thick, concrete mortar faced extruded polystyrene Lightguard Boards.

3. **Roof Covering*** — Consists of hot mopped or cold application bituminous materials compatible with insulation(s) described herein which provide Class A, B or C coverings. See Roofing Materials and Systems Directory-Roof Covering Materials.

A) In lieu of Item 3, roof covering consisting of single-ply **Roofing Membrane*** that is either ballasted, adhered or mechanically attached as permitted under the respective manufacturer's Classification. See Fire Resistance Directory - Roofing Membranes (CHCI).

4. **Gypsum Board*** — Any 5/8 in. thick UL Classified Gypsum Board that is eligible for use in Design Nos. L501, G512 or U305. Nom. 5/8 in. thick, supplied in 4 ft wide sheets. Min weight 2.0 psf. Installed perpendicular to steel roof deck with end joints staggered and offset from steel roof deck side lap joints. Secured to crests of steel roof deck with steel fasteners (Item 5) in a 24 in. grid.

CABOT MANUFACTURING ULC (View Classification) — CKNX.R25370

AMERICAN GYPSUM CO (View Classification) — CKNX.R14196

BEIJING NEW BUILDING MATERIALS PUBLIC LTD CO (View Classification) — CKNX.R19374

CERTAINTED GYPSUM INC (View Classification) — CKNX.R3660

CGC INC (View Classification) — CKNX.R19751

CONTINENTAL BUILDING PRODUCTS OPERATING CO, L L C (View Classification) — CKNX.R18482

GEORGIA-PACIFIC GYPSUM L L C (View Classification) — CKNX.R2717

LOADMASTER SYSTEMS INC (View Classification) — CKNX.R11809

NATIONAL GYPSUM CO (View Classification) — CKNX.R3501

PABCO BUILDING PRODUCTS L L C, DBA PABCO GYPSUM (View Classification) — CKNX.R7094

PANEL REY S A (View Classification) — CKNX.R21796

SIAM GYPSUM INDUSTRY (SARABURI) CO LTD (View Classification) — CKNX.R19262

THAI GYPSUM PRODUCTS PCL (View Classification) — CKNX.R27517

UNITED STATES GYPSUM CO (View Classification) — CKNX.R1319

USG BORAL DRYWALL SFZ LLC (View Classification) — CKNX.R38438

USG MEXICO S A DE C V (View Classification) — CKNX.R16089

5. **Fasteners** — (Not Shown) — For attaching gypsum wallboard to steel deck. **Steel Nails** — 2-1/8 in. long and 0.162 in. diam with a 19/64 in. diam flat head to be fabricated from case hardened steel with the shaft containing two types of serrations. The upper serration, approx 1/8 in. long, begins 1/4 in. from the nail head and the second serration begins 5/8 in. from the head with a spiral pattern 11/16 in. wide. A steel disc 0.020 in. thick and 2-1/8 in. min diam with a 7/32 in. prepunched center hole is to be used with each nail. Nails are to be installed with an automatic nailer. **Steel Insulation Clips** — Fabricated from a single piece of steel 0.033 in. thick and 5/8 in. max width. Length of stem to be 2-3/8 in. with stem curved and end pointed and having five barbs 5/16 in. long. A steel disc 0.011 in. thick and 2-11/16 in. min diam is to be used with each clip. Spacing of fasteners to be 24 in. O.C. across the width of the panel beginning 12 in. from the side edges and 24 in. along the length of the panel beginning 12 in. from the end.

6. **Steel Roof Deck** — Unclassified — Min 24 in. wide, 1-1/2 to 3 in. deep, galv fluted steel deck. Min gauge is 22 MSG. Flutes approx 6 in. O.C., crests approx 3-1/2 in. wide, valleys approx 1-3/4 in. wide. Welded to supports 12 in. O.C. Adjacent units welded 36 in. O.C. along side lap joints. Or, Classified Steel Floor and Form Units* — Noncomposite 1-1/2 to 3 in. deep, 24 to 36 in. wide, min 22 MSG galv steel fluted units. Welded to supports 12 in. O.C. Adjacent units button-punched or welded together 36 in. OC along side joints.

CANAM STEEL CORP — Type P-3606, P-3615, P-2436, and P-2404 noncomposite.

MARLYN STEEL DECKS INC — Types B, F, N, NV.

NEW MILLENNIUM BUILDING SYSTEMS L L C — 24 to 36 in. wide Types B, BD, BI, F, FD; 24 in. wide Type N, ND. Units may be phos/painted or galvanized.

VULCRAFT, DIV OF NUCOR CORP — Types BW, B High Strength, BW High Strength, N. Units may be panited/painted, 36 in. wide Type 1.5B , 24 in. wide Type 3NI. 32 in. wide Types 3NL-32, 3NI-32, 3PLN-32.

7. **Spray-Applied Fire Resistive Materials*** — Applied by mixing with water and spraying in more than one coat to a final thickness as shown above and on the table below, to steel surfaces which must be clean and free of dirt, loose scale and oil. Min avg and min ind density of 15/14 pcf respectively. Min avg and min ind density of 19/18 pcf respectively for Types 7GP and 7HD. For method of density determination, refer to Design Information Section.

Restrained & Unrestrained Assembly Rating Hr	Unrestrained Beam Rating Hr	Spray Applied Resistive Mtl	
		Thkns on Deck In.	Thkns on Beam In.
1	1	3/4	7/8
1	2	3/4	1-1/4
1-1/2	1-1/2	1-1/8	1
1-1/2	2	1-1/8	1-1/4
2	2	1-9/16	1-1/4

ARABIAN VERMICULITE INDUSTRIES — Types MK-6/CBF, MK-6/ED, MK-6/HY, MK-6/HB, MK-6s, MK-10 HB, MK-10 HB Extended Set, Sonophone 1.

GCP KOREA INC — Types MK-6/CBF, MK-6/ED, MK-6/HY, MK-6/HB, MK-6s, MK-10 HB, MK-10 HB Extended Set, Monokote Acoustic 1.

PYROK INC — Type LD.

SOUTHWEST FIREPROOFING PRODUCTS CO — Types 4, 5, 5EF, 5GP, 5MD, 7GP, 7HD, 8EF, 8GP, 8MD, 9EF, 9GP, 9MD.

GCP APPLIED TECHNOLOGIES INC — Types MK-6/HY, MK-6/HB, MK-6s, MK-10 HB, MK-10 HB Extended Set, Monokote Acoustic 1, RG.

8. **Metal Lath** — (Not Shown) — Where Type 7HD is applied to steel deck, 3/8 in. metal ribbed lath weighing 3.4 lb/yd² shall be secured to the underside of the steel deck (ribs upward) with S-12 by 3/8 in. long pan head, self-tapping steel screws spaced 12 in. OC in all directions. Steel screws shall be fitted with 1/2 in. diameter steel washers. Adjacent pieces of lath shall be overlapped 1 in. min.

*** Indicates such products shall bear the UL or cUL Certification Mark for jurisdictions employing the UL or cUL Certification (such as Canada), respectively.**

Last Updated on 2020-03-11

The appearance of a company's name or product in this database does not in itself assure that products so identified have been manufactured under UL's Follow-Up Service. Only those products bearing the UL Mark should be considered to be Certified and covered under UL's Follow-Up Service. Always look for the Mark on the product.

UL permits the reproduction of the material contained in the Online Certification Directory subject to the following conditions: 1. The Guide Information, Assemblies, Constructions, Designs, Systems, and/or Certifications (files) must be presented in their entirety and in a non-misleading manner, without any manipulation of the data (or drawings). 2. The statement "Reprinted from the Online Certifications Directory with permission from UL" must appear adjacent to the extracted material. In addition, the reprinted material must include a copyright notice in the following format: "© 2020 UL LLC"