

F Rating — 1 Hr
T Rating — 1/2 Hr

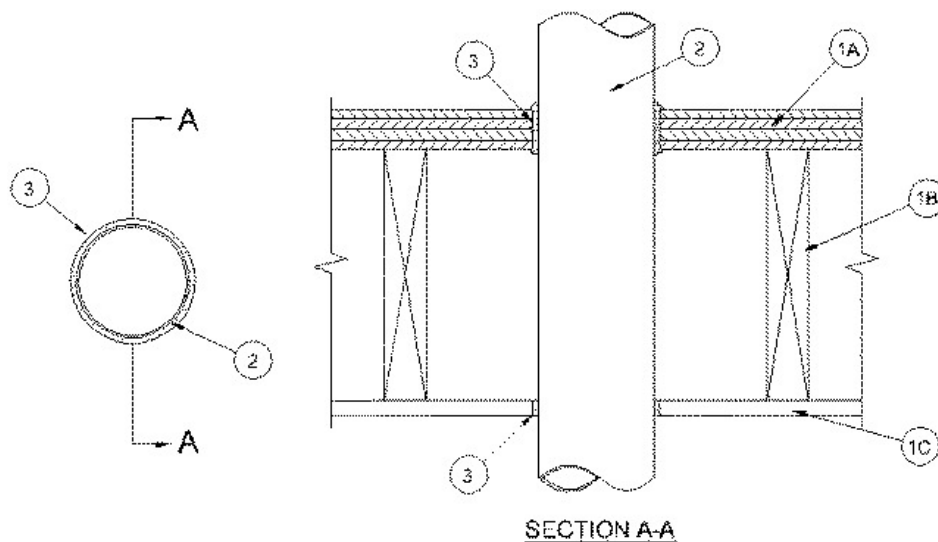

1. Floor-Ceiling Assembly — The 1 hr fire-rated wood joist floor-ceiling assembly shall be constructed of the materials and in the manner specified in the individual L500 Designs in the UL Fire Resistance Directory, as summarized below:

A. Flooring System — Lumber or plywood subfloor with finish floor of lumber, plywood or **Floor Topping Mixture*** as specified in the individual Floor-Ceiling Design. Max diam of opening is 5 in. (127 mm)

B. Wood Joists — Nom 10 in. (254 mm) deep (or deeper) lumber, steel or combination lumber and steel joists, trusses or **Structural Wood Members*** with bridging as required and with ends firestopped.

C. Wallboard, Gypsum* — Nom 5/8 in. (16 mm) thick as specified in the individual Floor-Ceiling Design.

2. Through Penetrant — One metallic pipe installed concentrically or eccentrically within the firestop system. A nom annular space of min 0 in. (point contact) to max. 1/2 in. (13 mm) is required between the penetrant and the periphery of the opening. Pipe or tubing to be rigidly supported on each side of the floor assembly. The following types and sizes of metallic pipes or tubing may be used:

A. Conduit — Nom 4 in. (102 mm) diam (or smaller) electrical metallic tubing or steel conduit.

B. Steel Pipe — Nom 4 in. (102 mm) diam or (smaller) sch 10 (or heavier) steel pipe.

C. Iron Pipe — Nom 4 in. (102 mm) (or smaller) cast or ductile iron pipe.

D. Copper Pipe — Nom 4 in. (102 mm) diam (or smaller) regular (or heavier) copper pipe.

3. Firestop System — The firestop system shall consist of the following:

A. Fill, Void or Cavity Material* - Caulk — Min 3/4 in. (19 mm) thickness of fill material applied within annulus, flush with top surface of subfloor and min 1/2 in. (13 mm) thickness of fill material applied within the annulus, flush with bottom surface of ceiling. 5/8 in. (16 mm) thickness of fill for use with penetrant D. At point contact location, 1/2 in. (13 mm) diam bead of caulk applied at interface of pipe and periphery of opening on top surface of floor and bottom surface of ceiling.

RECTORSEAL — [MC 150+](#), [Metacaulk 1000](#)

*,+ Indicates such products shall bear the UL or cUL Certification Mark for jurisdictions employing the UL or cUL Certification (such as Canada), respectively.

Reprinted from the Online Certifications Directory with permission from UL. ©UL LLC