

ANSI/UL1479 (ASTM E814)	CAN/ULC S115
F Rating — 1 Hr	F Rating — 1 Hr
T Rating — 1 Hr	FT Rating — 1 Hr
L Rating At Ambient — Less Than 1 CFM/sq ft	FH Rating — 1 Hr
L Rating At 400 F — Less Than 1 CFM/sq ft	FTH Rating — 1 Hr
	L Rating At Ambient — Less Than 1 CFM/sq ft
	L Rating At 400 F — Less Than 1 CFM/sq ft

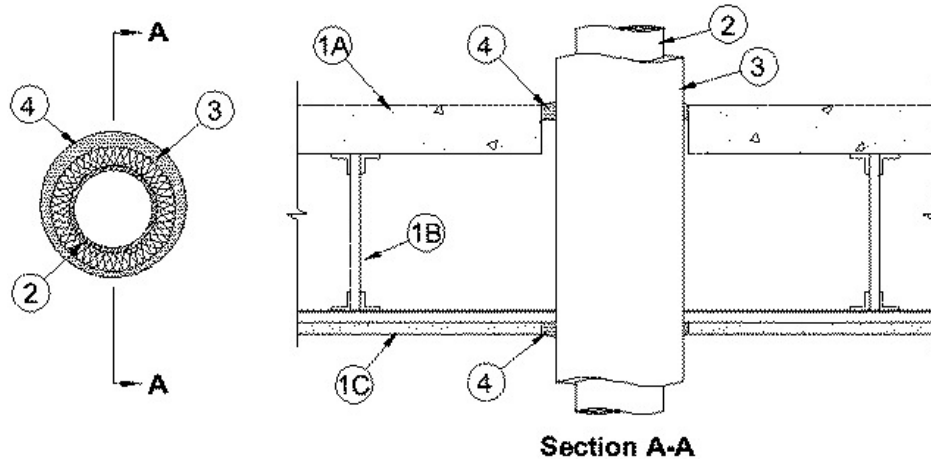

1. Floor-Ceiling Assembly — The 1 hr fire-rated concrete and steel joist Floor-Ceiling assembly shall be constructed of the materials and in the manner described in the individual G500 Series Design in the UL Fire Resistance Directory, as summarized below:

- A. Concrete Floor** — Normal weight or lightweight (100-150 pcf or 1600-2400 kg/m³) concrete over metal lath or steel deck as specified in the individual G500 Series Design. Max diam of floor opening is 4-3/4 in. (121 mm).
- B. Joists** — Steel joists or **Structural Steel Members*** as specified in the individual G500 Series Design.
- C. Gypsum Board*** — Min 5/8 in. (102 mm) thick, screw-attached to furring channels as specified in the individual G500 Series Design. Max diam of ceiling is 4-3/4 in. (121 mm).

2. Through Penetrant — One metallic pipe or tubing to be installed approximately midway between joists and installed either concentrically or eccentrically within the firestop system. Pipe or tubing to be rigidly supported on both sides of floor-ceiling assembly. The following types and sizes of metallic pipes or tubing may be used:

- A. Steel Pipe** — Nom 1-1/2 in. (38 mm) diam (or smaller) Schedule 10 (or heavier) steel pipe.
- B. Iron Pipe** — Nom 1-1/2 in. (38 mm) diam (or smaller) cast or ductile iron pipe.
- C. Copper Tubing** — Nom 1-1/2 in. (38 mm) diam (or smaller) Type L (or heavier) copper tubing.
- D. Copper Pipe** — Nom 1-1/2 in. (38 mm) diam (or smaller) Regular (or heavier) copper tubing. The max diam of the through penetrant is dependent upon the type of pipe covering (Item 3). If the tube insulation is used, the max diam of the through penetrant shall be nom 1 in. (25 mm). If a fiberglass or mineral wool pipe covering is used the max diam of the through penetrant shall be nom 1-1/2 in. (38 mm).

3. Pipe Coverings — One of the following types of pipe coverings shall be used:

- A. Pipe and Equipment Covering Materials*** — Nom 1 in. (25 mm) thick hollow cylindrical glass fiber units, nom 3.5 pcf (56 kg/m³) density, jacketed on the outside with an all service jacket. Longitudinal joints sealed with metal fasteners or factory-applied self-sealing lap tape. Transverse joints secured with metal fasteners or with butt tape supplied with the product. The annular space between the insulated penetrating item and the periphery of the opening shall be a min of 1/2 in. (13 mm) to a max of 5/8 in. (16 mm).

See **Pipe and Equipment Covering-Materials** - (BRGU) category in the Building Materials Directory for names of manufacturers. Any pipe covering material meeting the above specifications and bearing the UL Classification Marking with a Flame Spread Index of 25 or less and a Smoke Developed Index of 50 or less may be used.

- B. Pipe Covering Materials*** — Nom 1 in. thick mineral fiber pipe insulation having a nom density of 3.5 pcf (56 kg/m³) (or

heavier) and sized to the outside diam of pipe or tube. Pipe insulation secured with min 8 AWG steel wire space max 12 in. (305 mm) OC. The annular space between the insulated through penetrant and the periphery of the opening shall be a min of 1/2 in. (13 mm) to a max 5/8 in. (16 mm).

INDUSTRIAL INSULATION GROUP L L C — High Temperature Pipe Insulation 1200, High Temperature Pipe Insulation Pipe BWT or High Temperature Pipe Insulation Pipe Thermaloc

C. Sheathing Material* — Used in conjunction with Item 3B. Foil-scrim-kraft or all service jacket material shall be wrapped around the outer circumference of the pipe insulation (Item 3B) with the kraft side exposed. Longitudinal joints and transverse joints sealed with metal fasteners or butt tape.

See **Sheathing Materials** (BVDV) category in the Building Materials Directory for names of manufacturers. Any sheathing material meeting the above specifications and bearing the UL Classification Marking with a Flame Spread Index of 25 or less and a Smoke Developed Index of 50 or less may be used.

D. Tube Insulation — Plastics# — Nom 3/4 in. (19 mm) thick acrylonitrile butadiene/polyvinyl chloride (AB/PVC) flexible foam furnished in the form of tubing. Tube insulation to be installed on a one or more of the metallic pipes or tubing. The annular space between the insulated through penetrant and the periphery of the opening shall be a min of 1/4 in. (6 mm) to a max 5/8 in. (16 mm).

See **Plastics#** (QMFZ2) category in the Plastics Recognized Component Directory for names of manufacturers. Any Recognized Component tube insulation material meeting the above specifications and having a UL 94 Flammability Classification of 94-5VA may be used.

4. Fill, Void or Cavity Material* — Sealant — Min 3/4 in. (19 mm) thickness of fill material applied within the annulus, flush with top surface of floor. Min 5/8 in. (16 mm) thickness of fill material applied within the annulus, flush with bottom surface of ceiling. On both the top and bottom surfaces of the assembly, a min 1/4 in. (6 mm) thick crown of fill material is applied around the insulated through penetrant on both the top and bottom of the assembly.

RECTORSEAL — FlameSafe FS 1900, [Metacaulk 1000](#), [Metacaulk 350i](#), Biostop 350i or Biostop 500+

#Bearing the UL Recognized Component Mark

*,+ Indicates such products shall bear the UL or cUL Certification Mark for jurisdictions employing the UL or cUL Certification (such as Canada), respectively.

Reprinted from the Online Certifications Directory with permission from UL. ©UL LLC