

F Rating - 2 Hr
T Rating - 1-1/2 Hr

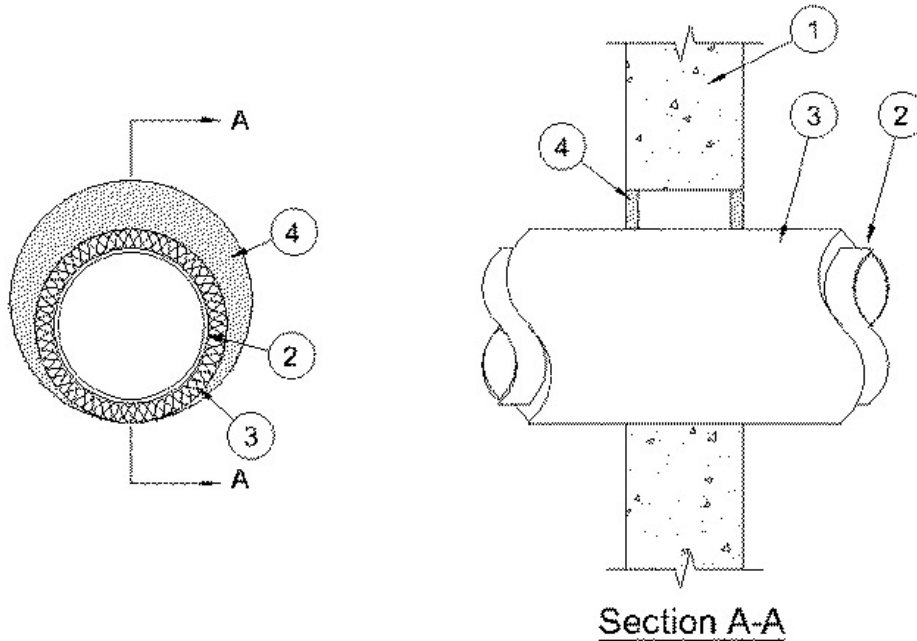

1. Wall Assembly — Min 6 in. thick reinforced lightweight or normal weight (100-150 pcf or 1600-2400 kg/m³) concrete. Wall may also be constructed of any UL Classified **Concrete Blocks***. Max diam of opening is 12-1/2 in (318 mm).

See **Concrete Blocks** (CAZT) category in the Fire Resistance Directory for names of manufacturers.

2. Through Penetrant — One metallic pipe to be installed either concentrically or eccentrically within the firestop system. Pipe to be rigidly supported on both sides of wall assembly. The following types and sizes of metallic pipes may be used:

A. **Steel Pipe** — Nom 8 in. (203 mm) diam (or smaller) Schedule 10 (or heavier) steel pipe.

B. **Iron Pipe** — Nom 8 in. (203 mm) diam (or smaller) cast or ductile iron pipe.

3. Pipe Covering* — Nom 1 in. (25 mm) thick hollow cylindrical heavy density min 3.5 pcf (56 kg/ m³) glass fiber units jacketed on the outside with an all service jacket. Longitudinal joints sealed with metal fasteners or factory-applied self-sealing lap tape. Transverse joints secured with metal fasteners or with butt tape supplied with the product. The annular space shall be min 0 in. (point contact) to max 1-7/8 in (48 mm).

See Pipe and Equipment Covering — Materials (BRGU) category in the Building Materials Directory for names of manufacturers. Any pipe covering material meeting the above specifications and bearing the UL Classification Marking with a Flame Spread Index of 25 or less and a Smoke Developed Index of 50 or less may be used.

4. Fill, Void or Cavity Materials* - Caulk — Min 5/8 in. (16 mm) thickness of caulk applied within annular space flush with each surface of wall. A min 1/4 in. (6 mm) diam bead of caulk shall be applied to the pipe insulation/gypsum board interface at the point contact location on both sides of wall.

RECTORSEAL — MC 150+

*,+ Indicates such products shall bear the UL or cUL Certification Mark for jurisdictions employing the UL or cUL Certification (such as Canada), respectively.

Reprinted from the Online Certifications Directory with permission from UL. ©UL LLC