

**Assembly Rating — 1 and 2 Hr (See Item 2)
Nominal Joint Width - 1 In.
Class II and III Movement Capabilities - 20% Compression Or Extension**

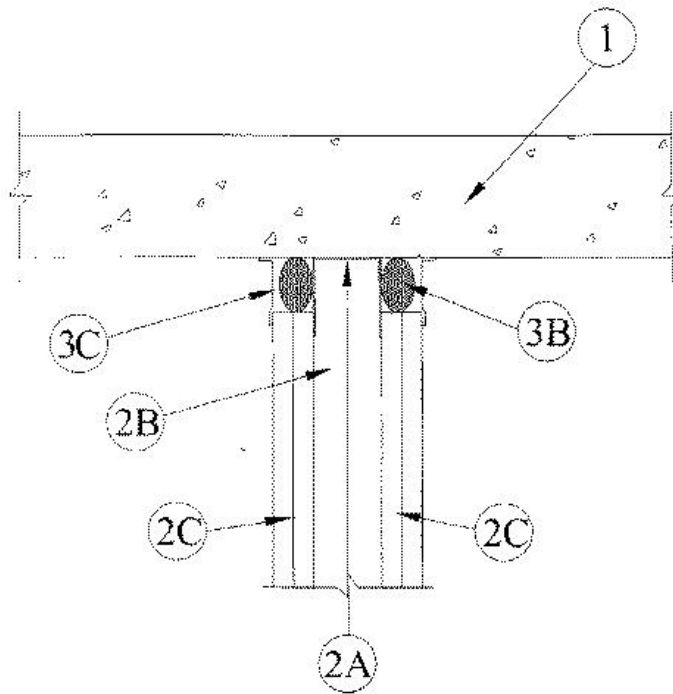

1. **Floor Assembly** — Min 5-1/2 in. thick reinforced light weight or normal weight (100~~150~~ pcf) structural concrete.

2. **Wall Assembly** — The 1 or 2 hr fire rated gypsum board/steel stud wall assembly shall be constructed of the materials and in the manner described in the individual U400 or V400 Series Wall and Partition Design in the UL Fire Resistance Directory and shall include the following construction features:

A. **Steel Floor and Ceiling Runners** — Floor and ceiling runners of wall assembly shall consist of galv steel channels sized to accommodate steel studs (Item 2B). Ceiling runner to be provided with 2 in. flange. When U-shaped deflection channel (Item 3A) is used, ceiling runner is installed within the U-shaped deflection channel with a 5/8 in gap maintained between the top of the ceiling runner and the top of the deflection channel. When deflection channel is not used, ceiling runner secured to concrete floor slab with steel masonry anchors spaced max 24 in. OC.

A1. **Light Gauge Framing*** — Slotted Ceiling Runner - As an alternative to the ceiling runner in Item 2A, slotted ceiling runner to consist of galv steel channel with slotted flanges sized to accommodate steel studs (Item 2B). Slotted ceiling runner secured to concrete floor slab with steel masonry anchors spaced max 24 in. OC. When slotted ceiling runner is used, deflection channel (Item 3A) shall not be used.

CEMCO, LLC — CST

BRADY CONSTRUCTION INNOVATIONS INC, DBA SLIPTRACK SYSTEMS — SLP-TRK

MARINO/WARE, DIV OF WARE INDUSTRIES INC — Type SLT

A2. **Light Gauge Framing*** — **Clipped Ceiling Runner** — As an alternate to the ceiling runner in Items 2A and 2A1, clipped runner to consist of galv steel channel with clips preformed in track flanges which positively engage the inside flange of the steel studs (Item 2B). Track sized to accommodate steel studs (Item 2B). Track flanges to be min 2-1/2 in. Clipped ceiling runner installed to concrete floor slab with steel masonry anchors spaced max 24 in. OC. When clipped ceiling runner is used, deflection channel (Item 3A) shall not be used.

TOTAL STEEL SOLUTIONS L L C — Snap Trak

A3. **Light Gauge Framing*- Notched Ceiling Runner** — As an alternate to the ceiling runners in Items 2A through 2A2, notched ceiling runners to consist of C-shaped galv steel channel with notched return flanges sized to accommodate steel studs (Item 2B). Notched ceiling runner secured to concrete floor slab with steel masonry anchors spaced max 24 in. OC. When notched ceiling runner is used, deflection channel (Item 3A) shall not be used.

OLMAR SUPPLY INC — Type SCR

B. Studs — Steel studs to be min 3-1/2 in. wide. Studs cut 5/8 in. less in length than assembly height with bottom nesting in and resting on floor runner and with top nesting in ceiling runner. Studs secured to floor runners with sheet metal screw. When deflection channel is used, studs are attached to ceiling runners with sheet metal screws a min. 1/2 in. above the bottom of deflection channel. When deflection channel is not used, studs shall not be attached to ceiling runner. When slotted ceiling runner (Item 2A1) is used, steel studs secured to slotted ceiling runner with No. 8 x 1/2 in. long wafer head steel screws at midheight of slot on each side of wall. Stud spacing not to exceed 24 in. OC.

C. Gypsum Board* — Gypsum board sheets installed to a min total thickness of 5/8 in. or 1-1/4 in. on each side of wall for 1 or 2 hr fire rated assemblies, respectively. Wall to be constructed as specified in the individual Wall and Partition Design in the UL Fire Resistance Directory, except that a nom 1 in. gap shall be maintained between the top of the gypsum board and the bottom of floor. The top row of screws shall be installed into the studs 3 in. below the top edge of the gypsum board.

3. Joint System — Max separation between bottom of floor and top of wall at time of installation of joint system is 1 in. The joint system is designed to accommodate a max 20 percent compression or extension from its installed width. The joint system consists of a packing material and a fill material, with or without a deflection channel, as follows:

A. Deflection Channel (Optional) — A nom 3-1/2 in. wide by min 2 in. deep, min 24 galv steel U-shaped channel. Deflection channel secured to concrete floor slab with steel masonry anchors spaced max 24 in. OC. The ceiling runner (Item 2A) is installed within the deflection channel to maintain a 5/8 in. gap between the top of the ceiling runner and the top of the deflection channel. The ceiling runner is not fastened to the deflection channel.

B. Packing Material* — Foam backer rod firmly packed into gap between top of gypsum board and bottom of concrete floor as a permanent form. Forming material is to be recessed from each surface of wall to accommodate the required thickness of fill material.

C. Fill, Void or Cavity Material* — Min 1/4 in. wet thickness of fill material sprayed or troweled on each side of the wall to completely cover packing material and to overlap a min of 1/2 in. onto wall and floor on both sides of wall.

RECTORSEAL — [Metacaulk 1000](#) or Metacaulk 1100

* Indicates such products shall bear the UL or cUL Certification Mark for jurisdictions employing the UL or cUL Certification (such as Canada), respectively.