

Assembly Ratings - 2 and 3 Hr (See Items 1 and 1A)
Nominal Joint Width - 1 in.
Class II Movement Capabilities - 19 % Compression or Extension
L Rating At Ambient - Less Than 1 CFM/Lin Ft
L Rating At 400 F - Less Than 1 CFM/Lin Ft

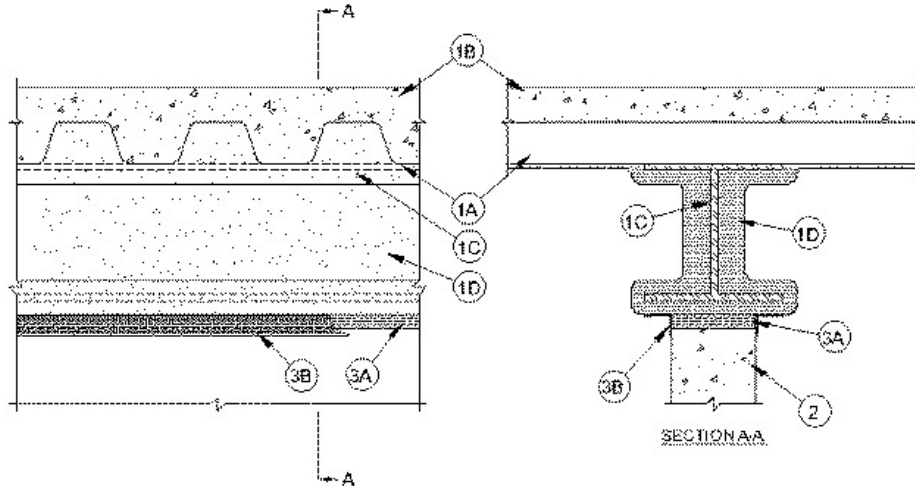

1. Floor Assembly — The fire-rated fluted steel deck/concrete floor assembly shall be constructed of the materials and in the manner described in the individual D700 Series Floor-Ceiling Design in the UL Fire Resistance Directory and shall include the following construction features:

A. Steel Floor And Floor Units* — Max 3 in. (76 mm) deep galv steel fluted floor units.

B. Concrete — Min 2-1/2 in. (64 mm) thick reinforced concrete, as measured from the top plane of the floor units.

C. Structural Steel Support — Steel beam, as specified in the individual D700 Series Floor-Ceiling Design, used to support steel floor units. Steel beam centered over and parallel with wall assembly.

D. Spray-Applied Fire Resistive Material* — Steel floor units and structural steel support to be sprayed with the min thickness of material specified in the individual D700 Series Design. The flutes of the steel floor units are to be filled with material across the entire top flange of the steel beam. **Additional material shall be applied to the web of the steel beam on each side of the wall. The min total thickness of material applied to each side of the steel beam web shall be 1-3/8 in. (35 mm) and 1-9/16 in. (40 mm) for 2 and 3 hr assembly rating, respectively.**

GCP APPLIED TECHNOLOGIES INC — Type MK-6/HY , MK-6/HY ES, RG and MK-6S.

The hourly fire rating of the floor assembly shall be equal to or greater than the hourly fire rating of the wall assembly.

1A. Roof Assembly — (Not Shown) — As an alternate to the floor assembly, a fire-rated fluted steel deck roof assembly may be used. The roof assembly shall be constructed of the materials and in the manner described in the individual P900 or P700 Series Roof-Ceiling Design in the UL Fire Resistance Directory.. The roof assembly shall include the following construction features:

A. Steel Roof Deck — Max 3 in. (76 mm) deep galv steel fluted roof deck.

B. Roof Insulation — For P900 Series Designs, min 2-1/4 in. (57 mm) thick poured insulating concrete, as measured from the top plane of the roof deck. For P700 Series Designs, roof insulation shall be as specified in the individual design.

C. Structural Steel Support — Steel beam, as specified in the individual P700 or P900 Series Floor-Ceiling Design, used to support steel floor units. Steel beam centered over and parallel with wall assembly.

D. Spray-Applied Fire Resistive Material* — (Not Shown) Prior to the installation of the joint system (Item 3) all surfaces of the roof deck to be sprayed with the thickness of material specified in the individual P700 Series Design. For D900 Series Designs structural steel supports only to be sprayed in accordance with the specifications in the individual P900 Series Design. The flutes of the steel roof deck are to be filled with material across the entire top flange of the steel beam. **Additional material shall be applied to the web of the steel beam on each side of the wall. The min total thickness of material applied to each side of the steel beam web shall be 1-3/8 in (35 mm) and 1-9/16 in. (40 mm) for 2 and 3 hr assembly rating, respectively.**

GCP APPLIED TECHNOLOGIES INC — Type MK-6/HY, MK-6/HY ES, RG and MK-6S.

The hourly fire rating of the roof assembly shall be equal or greater than the hourly fire rating of the wall assembly.

2. **Wall Assembly** — Min 6 in. (152 mm) thick reinforced lightweight or normal weight (100-150 pcf or 1600-2400 kg/m³) structural concrete. Wall may also be constructed of any UL Classified **Concrete Blocks***. See **Concrete Blocks*** (CAZT) category in the Fire Resistance Directory for names of manufacturers.

The hourly fire rating of the joint system is equal to the hourly rating of the wall assembly.

3. **Joint System** — Max separation between spray applied fire resistive material on bottom of structural support member and top of wall (at time of installation of joint system) is 1 in. (25 mm). The joint system is designed to accommodate a max 19 percent compression or extension from its installed width as measured between bottom plane of the protective material on the steel beam and the top of the wall. The joint system shall consist of forming and fill materials, as follows:

A. **Forming Material*** — Min 6 in. (152 mm) or 6-5/8 in. (168 mm) wide sections of nom 4 pcf (64 kg/m³) mineral wool batt insulation, for 2 and 3 hr rated assemblies, respectively, to be compressed 50 percent in thickness and installed cut edge first to completely fill the gap above the top of the concrete wall. The forming material shall be installed flush with both surfaces of wall.

INDUSTRIAL INSULATION GROUP L L C — MinWool-1200 Safing

JOHNS MANVILLE — Safing

ROCK WOOL MANUFACTURING CO — Delta Safing Board

ROCKWOOL MALAYSIA SDN BHD — SAFE

ROCKWOOL — SAFE

THERMAFIBER INC — SAF

B. **Fill, Void or Cavity Material* - Sealant** — Min 1/8 in. (3.2 mm) wet thickness or 1/16 in. (1.6 mm) dry thickness of fill material spray applied over the forming material on each side of the wall. Fill material to overlap min 1/2 in. (13 mm) onto concrete wall and min 2 in. (51 mm) onto the spray applied material (Item 1D) on the steel beam on both sides of wall. **RECTORSEAL** — FlameSafe FS3000, [Metacaulk 1200, 1500](#) or Biostop 750, 800 Spray

*,+ Indicates such products shall bear the UL or cUL Certification Mark for jurisdictions employing the UL or cUL Certification (such as Canada), respectively.

Reprinted from the Online Certifications Directory with permission from UL. ©UL LLC