

F Rating — 2 Hr
T Rating — 0 Hr

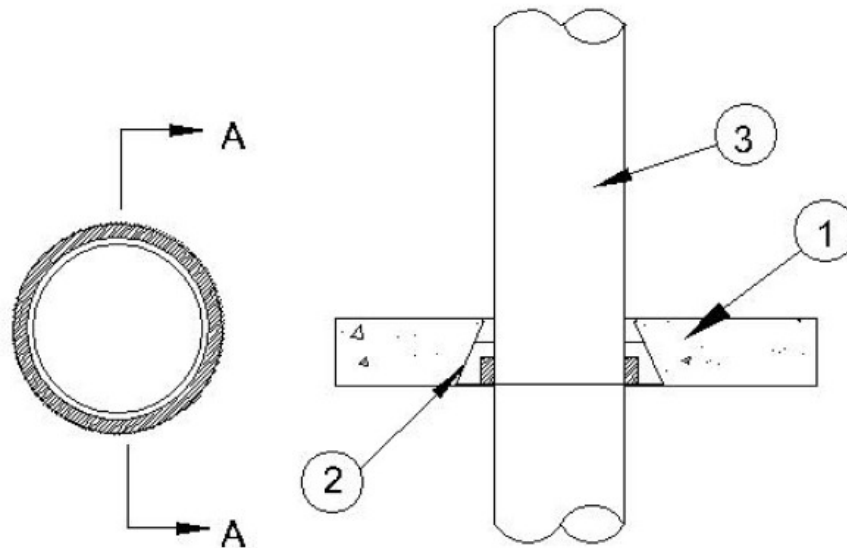

Section A-A

1. **Floor Assembly** — Min 2-1/2 in. (64 mm) thick reinforced lightweight or normal weight (100-150 pcf or 1600-2400 kg/m³) concrete.
2. **Firestop Devices*** — Cast in place firestop device permanently embedded during concrete placement in accordance with accompanying installation instructions. The device may project up to a max of 3-1/2 in. (89 mm) above top surface of floor or trimmed flush with top surface of floor. The devices are provided in nom 2 in. (51 mm) and 4 in. (102 mm) size.
RECTORSEAL — Biostop or [Rectorseal Cast-in-Place Firestop Device](#)
3. **Through Penetrants** — One metallic pipe, tubing or conduit installed within the firestop system. Penetrant to be rigidly supported on both sides of floor assembly. The penetrant size shall be nom 2 in. (51 mm) diam for nom 2 in. device and nom 4 in. (102 mm) diam. for the nom 4 in. device. The following types of metallic penetrants may be used:
 - A. **Steel Pipe** — Schedule 5 (or heavier) steel pipe.
 - B. **Iron Pipe** — Cast or ductile iron pipe.
 - C. **Conduit** — Steel conduit or steel electrical metallic tubing.
 - D. **Copper Tubing** — Type L (or heavier) copper tubing.
 - E. **Copper Pipe** — Regular (or heavier) copper pipe.

*,+ Indicates such products shall bear the UL or cUL Certification Mark for jurisdictions employing the UL or cUL Certification (such as Canada), respectively.

Reprinted from the Online Certifications Directory with permission from UL. ©UL LLC