

Centre Scientifique et  
Technique du  
Bâtiment

84 avenue Jean Jaurès  
CHAMPS-SUR-MARNE  
F-77447 Marne-la-Vallée Cedex 2

Tél. : (33) 01 64 68 82 82

Fax : (33) 01 60 05 70 37

**European Technical  
Assessment**

**ETA-17/0893  
of 9<sup>th</sup> may 2018**

*English translation prepared by CSTB - Original version in French language*

**General Part**

Nom commercial  
*Trade name*

EMSHIELD DFR / EMSHIELD WFR

Famille de produit  
*Product family*

**Produits de compartimentage et de calfeutrement au feu :**  
**- Joints d'Étanchéité Linéaires**  
***Fire Stopping and Sealing Product :***  
**- *Linear Joint and Gap Seals***

Titulaire  
*Manufacturer*

EMSEAL Joint Systems Ltd.  
25 Bridle Lane Westborough,  
MA 01581 - U.S.A

Usine de fabrication  
*Manufacturing plant*

Plant 1

Cette évaluation contient:  
*This Assessment contains*

10 pages incluant 5 pages d'annexes qui font partie intégrante de cette évaluation. L'annexe C (pages 11 à 16 de la version française seulement) contient des informations confidentielles qui ne sont pas incluses dans l'Évaluation Technique Européenne quand elle est disponible au public.

*10 pages including 5 pages of annexes which form an integral part of this assessment. The annex C (pages 11 to 16 of the french version only) contains confidential information and is not included in the European Technical Assessment when that assessment is publicly available*

Base de l'ETE  
*Basis of ETA*

DEE 350141-00-1106 - Produits de compartimentage et de calfeutrement au feu : Joints d'Étanchéité Linéaires  
*EAD 350141-00-1106 - Fire Stopping and Sealing Product :  
Linear joint and gap seals*

## Specific Part

### 1 Technical description of the product

Emshield WFR and Emshield DFR are identical fire rated expansion joints used for different applications :

- Emshield DFR is used as joint seal in a floor or as horizontal wall joint abutting a floor, ceiling or roof (configurations A and D in figure 1 in EAD 350141-00-1106).
- Emshield WFR is used as vertical joint seal in a wall (configuration B in figure 1 in EAD 350141-00-1106).

They are made of dual-sided silicone sealing surfaces adhered to a fire-retardant impregnated polyurethane foam backing.

Emshield DFR and WFR must be applied using the component listed in table 1.1 below according to the installation described in annex A :

Name	Trade reference	Characteristics	Supplier
EPOXY ADHESIVE PART A and B (on the concrete substrate walls)	NOMAD	2-3mm of thickness	NORTHERN MANUFACTURING
	SIKADUR 31 CF	2-3mm of thickness	SIKA FRANCE
Linear joint	Emshield DFR or WFR	ρ polyurethane + silicone = 600 kg/m <sup>3</sup> +/- 5%, Silicone thickness = 2,5 to 4 mm (valleys : 1,5 mm +/- 0.5mm) total width = 12 to 100 mm (compressed) total thickness = 100 to 110 mm	EMSEAL Joint Systems Ltd
Sealant (between the joints)	Fire Barrier Sealant CP 25WB+	2-3mm thickness	3M™
Silicone sealant (interface between the joint and the substrate)	PECORA 890 NST	4-6mm diameter	PECORA Corporation
	Dow Corning® 790	4-6mm diameter	Dow Corning
	Dow Corning® 748	4-6mm diameter	Dow Corning
	PECORA DynaFlex	4-6mm diameter	PECORA Corporation

Table 1.1 : Component list

The seal is not sold as a kit, only Emshield DFR or WFR are covered by the ETA. It is the responsibility of the installer to obtain the other components for incorporation into the assembled system.

### 2 Specification of the intended use

#### 2.1 Intended use

The intended use of fire rated linear joints Emshield WFR and Emshield DFR is to reinstate the fire resistance performance of separating building elements where they are interrupted.

- 1) In the following specified constructions Emshield WFR and Emshield DFR may be used for sealing horizontal linear joints in floors, vertical linear joints in walls or horizontal linear joint abutting a floor, ceiling or roof, are as follows:

Rigid floors (DFR) :	For the joints with a movement capacity 100% (+/- 50%)* with lateral displacement of joint induced by the mechanically action (dynamic), the floors must have a minimum thickness of 150 mm comprise concrete, reinforced concrete and masonry, with a minimum density of 2400 kg/m <sup>3</sup>
Rigid walls (WFR) :	For the joints with a movement capacity 100% (+/- 50%)* with lateral displacement of joint induced by the mechanically action (dynamic), the walls must have a minimum thickness of 115 mm comprise concrete, reinforced concrete and masonry, with a minimum density of 2400 kg/m <sup>3</sup>

\* Maximum movement capacity according to the compression ratio (supplied size/nominal size)

- 2) The firestop linear joint seals Emshield WFR and Emshield DFR are not intended for load transmission.
- 3) Emshield WFR and Emshield DFR can be used to form a linear joint with a maximum permitted initial joint width from 12 mm to 100 mm with a mechanically induced lateral movement in the joint.
- 4) The performances given in section 3 are only valid if the joint is used in compliance with:
  - The specifications and conditions given in Annex B;
  - The manufacturer's instructions according to Annex A.

## 2.2 Working life

The provisions made in this European Technical Assessment are based on an assumed working life of Emshield WFR and Emshield DFR firestop joints of 10 years, provided that the conditions laid down in the manufacturers datasheet and instructions for the packaging / transport / storage / installation / use are met.

The indications given on the working life cannot be interpreted as a guarantee given by the producer, but are to be regarded only as a means for choosing the right products in relation to the expected economically reasonable working life of the works.

The real working life might be, in normal use conditions, considerably longer without major degradation affecting the Basic Requirements for construction works.

## 3 Performance of the product and references to the methods used for its assessment

### 3.1 Safety in case of fire (BWR 2)

Essential characteristic	Performance
Reaction to fire	Class according to EN 13501-1 : B - s2, d0
Resistance to fire	Class according to EN 13501-2 See Annex B

### 3.2 Hygiene, health and the environment (BWR 3)

Essential characteristic	Performance
Release of dangerous substances	The emission of dangerous substances was not assessed. No performance assessed

Air permeability	According to EN 1026 (tested with the other components listed in part 1) No leakage was measured
Water permeability	According to EN 12155 (tested with the other components listed in part 1) No leakage was measured

### 3.3 Safety and accessibility in use (BWR 4)

No performance assessed

### 3.4 Protection against noise (BWR 5)

Essential characteristic	Performance
Airborne sound insulation	According to EN 10140-2 (tested with the other component listed in part 1) The airborne sound insulation, expressed in accordance with EN ISO 717-1, is : $R_{s,w} (C, C_{tr}) \geq 54 (-1; -3)$ for two seals of length 1000mm and width 100mm arranged side by side in the length and tested with the other components listed in part 1.

### 3.5 Energy economy and heat retention (BWR 6)

No performance assessed

### 3.6 General aspects relating to fitness for use

Essential characteristic	Performance
Durability and serviceability	Type X : intended for use in conditions exposed to weathering

## 4 Assessment and verification of constancy of performance (AVCP)

According to the Decision 1999/454/EC of the European Commission<sup>1</sup>, the system of assessment and verification of constancy of performance (see Annex V to Regulation (EU) No 305/2011) given in the following table applies.

Product	Intended use	Level or class	System
<b>Fire Stopping and Fire Sealing Products</b>	For fire compartmentation and/or fire protection or fire performance	any	1

1

Official Journal of the European Communities L 178/52 of 14.7.1999

## **5 Technical details necessary for the implementation of the AVCP system**

Technical details necessary for the implementation of the Assessment and verification of constancy of performance (AVCP) system are laid down in the control plan deposited at Centre Scientifique et Technique du Bâtiment.

The manufacturer shall, on the basis of a contract, involve a notified body approved in the field of fire stopping and sealing products for issuing the certificate of conformity CE based on the control plan.

The Notified Body shall visit the factory at least twice a year for surveillance of the manufacturer.

**The original French version is signed by**

Charles Baloche  
Technical Director

## 1 Equipment & Material Storage

In addition to safety equipment required to comply with applicable federal, state and local safety regulations, equipment to prepare and repair the joint-faces, as well as normal tools of the trade, the following are required:

### Equipment Checklist:

- Tape measure
- Heavy duty electric, plug-in, low speed - high torque drill for mixing thick epoxy
- Min. 2 ea - 1 ½" diameter "jiffy mixers"
- Sausage gun & tips for 20-oz silicone sausages provided
- Sausage gun & tips for 20-oz intumescent sausages provided
- Long-bladed, serrated bread knife
- Hacksaw
- Spray bottle with water
- Duct tape (2 ½ times the length of joint)
- Spatula to scrape epoxy from can
- Chemical-resistant gloves
- 2-inch wide (50mm) margin trowels for applying epoxy adhesive on the material and for spreading intumescent sealant on exposed foam face.
- Caulk knives for tooling sealant bands
- Acetone\* for cleaning joint-faces, trowels and mixer tools
- Clean lint-free, 100% cotton rags

**Cold Days:** Store Sealant, off the floor, inside at above 68 °F (20 °C). It will recover slower when cold and faster when warm.

**Very Hot Days:** Keep sealant out of direct sun when the temperature is greater than 60 °F (15 °C) until immediately prior to installation into joint.

## 2 Prepare & Solvent-Wipe Joint Faces

### Concrete:

- Remove loose particles and weak concrete to ensure sound concrete substrate. Spalls, chipped edges and uneven surfaces must be repaired using suitable patching material and proper patching geometry and techniques. Joint faces must be parallel.
  - Joints must have unobstructed depth greater than or equal to the full depth of the largest material supplied plus 1/2-inch (6mm).
  - Remove all contaminants by sandblasting or grinding to ensure a thoroughly clean and sound substrate for the full sealant depth.
- NOTE:** DO NOT use a wire wheel—this will polish the substrate and cause bond-failure.
- Dry all wet surfaces.
- NOTE:** Do not use flame to dry substrate—this will leave carbon on the substrate and cause bond-failure.
- Wipe joint faces with solvent-dampened, lint-free rags to remove all concrete dust and contaminants.

**Other Substrates:** Contact EMSEAL.

## 3 Measure Joint Width & Find Correct Size Material

- Measure joint width at deck surface and below to ensure joint faces are parallel.
- Material has been supplied to suit your mean temperature field-measured joint widths. Widths of material supplied are marked on each stick of material. Find correct box and open it.
- Compare width of material supplied as marked on each stick against mean joint width. Actual width of material as measured between hardboard will be slightly less than marked size because material is over-compressed for ease of installation.

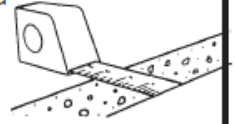

**NOTE:** If unsure of correct material selection, consult EMSEAL.

**IMPORTANT:** Do not remove outer plastic packaging until you have read and understand the rest of these instructions as material may expand prematurely.

## 4 Mask Deck & Mix Epoxy Adhesive

- Using duct tape, tape off the deck on both sides of the joint.

### Mix Epoxy

- EMSEAL epoxy adhesive may be used in the 41 °F (5 °C) to 95 °F (35 °C) temperature range.
- Using a trowel, transfer the entire contents of Part B (hardener) into the contents of Part A (base).
- Mix the material thoroughly with a drill and mixing paddle. Scrape the walls and bottom of the container to ensure uniform and complete mixing.
- Always mix component B (hardener) into component A (base). Ensure that a uniform gray color with no black or white streaks is obtained.

**IMPORTANT:** DO NOT thin the epoxy.

- **Precaution:** Wear chemical-resistant gloves and/or barrier hand cream when handling liquid sealant or epoxy. Remove promptly from skin with a commercial hand cleaner before eating or smoking. Avoid inhaling vapors.



### 5 Apply Epoxy to Both Substrates, Unwrap DFR2

Ensure that the mixed epoxy adhesive is applied to both substrate walls before the pot life has expired (10-30 minutes depending on the ambient temperature).

**WARNING:** Epoxy will harden more quickly when left in the pot. Apply it onto the joint face as soon as possible.

**IMPORTANT:** The epoxy must still be uncured when installing DFR foam into the joint-gap.

If the epoxy cures before installing the DFR foam then reapply new epoxy. If work is interrupted for more than 2 hours after initial cure then grind the old epoxy and apply new wet epoxy.

**IMPORTANT:** While one or more workers are applying epoxy to the joint faces, others must prepare the DFR foam. The DFR foam is kept under compression by plastic wrapping and hardboard on both sides.

- Slit the plastic packing by cutting on the hardboard and remove hardboard and inner release liner. DO NOT cut along the silicone bellows faces.

**IMPORTANT:** Work quickly and deliberately after cutting the shrink-wrap to avoid material expanding beyond a usable size.

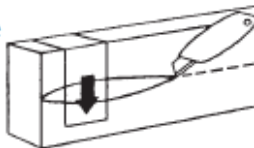
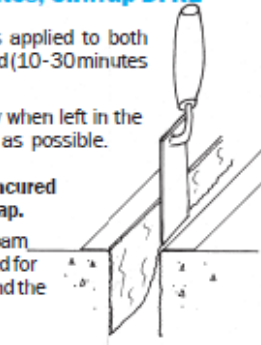

### 6 Wipe Release Agent off Silicone Facing of DFR2 Foam

- For packaging and production reasons, the silicone facing is coated in the factory with a release agent.
- Prior to installation, this agent must be wiped off in order for the injected sealant bands described in Step #9 to adhere to the silicone facing and to avoid contamination of the substrate at this point.
- Lightly, quickly and thoroughly wipe the cured silicone facing with a lint-free rag made damp with water to remove the release agent.

**TIP:** Use the hardboard packaging as a flat, clean working surface.

- **Clean Up:** Remove epoxy and silicone sealant from equipment before it cures using acetone\* or alternative solvent. Solvents are not effective after the epoxy or silicone has cured. Cured material may be removed by cutting it away with sharp tools or sandpapering. (\*Solvents can be considered toxic and flammable. Observe solvent manufacturer's precautions and refer to Material Safety Data Sheets as well as local and federal requirements for safe handling and use.)

### 7 Install First DFR2 Foam Length into Joint & Apply Silicone to Bellows Face

- **Both bellows faces are trafficable.** Either side can be installed as the top "traffic" face.
- Immediately install the foam into the joint. Ensure that epoxy on the joint face has not cured.
- When installed, the DFR2 must be recessed so that the top of the bellows is recessed 1/4-inch below the deck surface.
- Note: When material is correctly expanded for a snug fit it will support its own weight in the joint.
- Feed material into joint, starting from one end. The material should fit snugly and must be eased into the joint with steady, firm pressure.
- Leave the end to be joined to the next length sticking slightly proud of the joint.
- Repeat step #6 for each new stick.
- On the end of the next stick, using a sausage gun and the sausages of silicone provided, apply the liquid silicone to the exposed upper and lower end faces of silicone bellows.
- Using a sausage gun and the sausages of intumescent sealant provided, apply the intumescent sealant to the exposed end faces of the DFR2 foam.
- Use a caulk knife or margin trowel to spread the intumescent sealant over the face of the foam to an even 1/16th-inch (2mm) thickness.

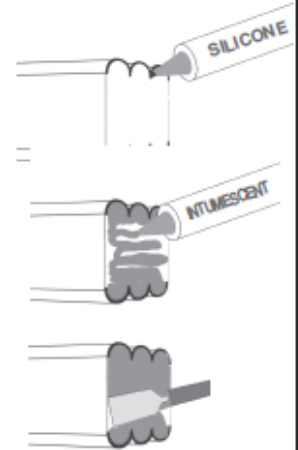

**IMPORTANT:** All sticks of DFR2 foam MUST have a coating of intumescent on the faces of all joints. This ensures that joints do not compromise the fire barrier.

### 8 Install Next Length. Repeat.

- Work in one direction towards the previously installed length or end of joint. Do not stretch material.
- Leave the end to be joined to the previous length sticking proud of the joint—push the joining faces together.
- **Push Hard** on the stick to compress joints firmly together. Ensure there are no voids at joints.
- Once the full length is installed, push the protruding joint into the joint and tool off the excess silicone.
- During low temperature installation, provide as much ambient heat as possible around installed DFR foam to accelerate recovery.

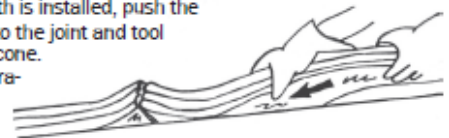

### 9 Inject Silicone Sealant Bands at Substrates & Tool Excess Silicone

- Wipe any excess epoxy from top of material using a clean rag.
- Before the epoxy cures, force the tip of the sausage caulk gun between the substrate and the DFR foam. Inject a 3/4-inch (20mm) deep silicone sealant band between the foam, cured silicone facing and the joint-face.
- Tool the freshly applied silicone firmly to blend with the substrates and cured silicone facing, and to ensure a proper bond and seamless appearance.

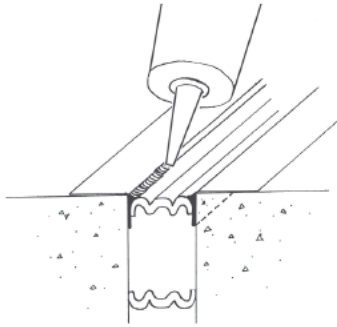

- Where DFR foam meets at butt joints, tool the excess silicone that squeezes out from the top and between the bellows. **IMPORTANT: Silicone left between the wrinkles of the bellows could constrain movement – using a caulk knife, remove excess sealant and blend what remains into the bellows.**
- **Note:** Silicone sealant band is only applied to the weather side of the DFR foam.

Installation conditions

Annex A



## FIRE RESISTANCE

Emshield WFR and Emshield DFR were tested according to EAD 350141-00-1106 clause 2.2.2 and EN 1366-4. Based upon the gained results and the field of application specified within EN 1366-4 the joints Emshield WFR and Emshield DFR have been classified according to EN 13501-2+A1:2013-03.

The fire resistance classes of the linear joints Emshield WFR and Emshield DFR in the relevant separating elements are valid for a lateral displacement of 50% maximum of the initial width and if they are installed according to annex A of the ETA.

### 1 - “DFR” joints

Emshield DFR is used as joint seal in a floor or as horizontal wall joint abutting a floor, ceiling or roof (configurations A and D in figure 1 in EAD 350141-00-1106)

Minimum density of the supporting construction in which DFR is used for linear joint:

Supporting construction	Minimum density
Rigid concrete floors	≥ 2400 kg/m <sup>3</sup>

Minimum thickness of the supporting construction in which DFR used for linear joint:

Supporting construction	Minimum thickness
Rigid concrete floors	≥ 150 mm of concrete

Lateral movement capability of DFR :

Movement capability	Linear joint
± 50 %	DFR

Installation and dimensions:

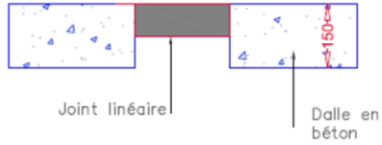
Dimensions	Position of joint
DFR joint with a maximum initial joint width from 12 mm to 100 mm and thickness of 100mm to 125mm	The joint is always installed on top 
Installation stages (according to annex A) :	
1/ Epoxy Adhesive A/B glue on substrate walls 2/ Emshield DFR joints installation 3/ “Fire Barrier Sealant” between the joints 4/ Silicone “Dow corning 790” applied between the joint and the substrate	

Classification
<b>EI240 – H – M50 – M – W 12 to 100</b>

The classement is only valid with conditions :

- Respect the arrangement and corresponding installation parameters;
- Fire is under the concrete floor

	<b>Annex B</b>
Fire resistance tests and classification	

- Respect configurations A and D in figure 1 in EAD 350141-00-1106 only
- Density and thickness of the supporting construction must be those required
- Respect the compression ratio of sealing joint.

## 2 - “WFR” joints

Emshield WFR is used as vertical joint seal in a wall (configurations B in figure 1 of EAD 350141-00-1106)

Minimum density of the supporting construction in which WFR is used for linear joint:

Supporting construction	Minimum density
Rigid concrete walls	≥ 2400 kg/m <sup>3</sup>

Minimum thickness of the supporting construction in which WFR used for linear joint:

Supporting construction	Minimum thickness
Rigid concrete walls	≥ 115 mm of concrete

Lateral movement capability of WFR :

Movement capability	Linear joint
± 50 %	WFR

Installation and dimensions:

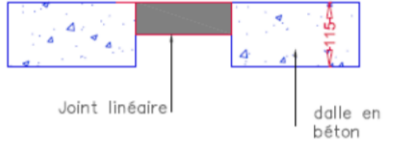
Dimensions	Position of joint
WFR joint with a maximum initial joint width from 12 mm to 100 mm and thickness of 110mm	<p>The joint is always installed on the unexposed side level</p> 
Installation stages (according to annex A) :	
<ol style="list-style-type: none"> <li>1/ Epoxy Adhesive A/B glue on substrate walls</li> <li>2/ Emshield WFR joints installation</li> <li>3/ “Fire Barrier Sealant” between the joints</li> <li>4/ Silicone “Dow corning 790” applied between the joint and the substrate</li> </ol>	

Classification
<b>EI180 – H – M50 – M – W 12 to 100</b>

The classement is only valid with conditions :

- Respect the arrangement and corresponding installation parameters;
- Fire on the opposite side of the joint
- Respect configuration B in figure 1 in EAD 350141-00-1106 only
- Density and thickness of the supporting construction must be those required
- Respect the compression ratio of sealing joint.

Fire resistance tests and classification

**Annex B**