

ANSI/UL2079	CAN/ULC S115
Assembly Ratings — 1 and 2 Hr (See Item 2)	F Ratings — 1 and 2 Hr (See Item 2)
Joint Width - 1/2 In. Max	FT Ratings — 1 and 2 Hr (See Item 2)
L Rating at Ambient — Less than 1 CFM/Lin Ft	FH Ratings — 1 and 2 Hr (See Item 2)
L Rating at 400 F — Less than 1 CFM/Lin Ft	FTH Ratings — 1 and 2 Hr (See Item 2)
	Joint Width — 13 mm. Max
	L Rating at Ambient — Less than 1 L/s/m
	L Rating at 400 F — Less than 1 L/s/m

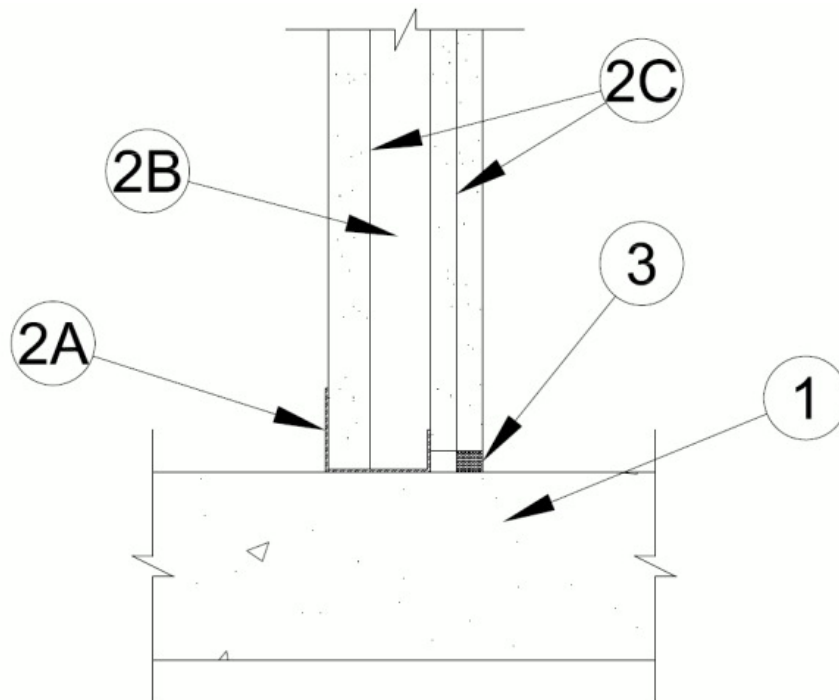

**1. Floor Assembly** — Min 4-1/2 in. (114 mm) thick reinforced lightweight or normal weight (100-150 pcf or 1600-2400 kg/m<sup>3</sup>) structural concrete. Floor may also be constructed of any min 6 in. (152 mm) thick UL Classified hollow-core **Precast Concrete Units\***.

See **Precast Concrete Units** (CFTV) category in the Fire Resistance Directory for names of manufacturers.

**2. Wall Assembly** — The 1 or 2 hr fire rated gypsum board/steel stud shaft wall assembly shall be constructed of the materials and in the manner specified in the individual U400, V400 or W400 Series Wall and Partition Design in the UL Fire Resistance Directory. In addition, the wall may incorporate a head-of-wall joint system constructed as specified in the HW Series Joint Systems in the UL Fire Resistance Directory. The wall shall include the following construction features:

**A. Steel Floor Runner** — "J"-shaped runners, minimum 2-1/2 in. (64 mm) deep, with unequal legs of 1 in. (25 mm) and 2 in. (51 mm), fabricated from min 24 MSG galv steel. Runners positioned with short leg toward finished side of wall. Runners attached to structural supports with steel fasteners located not greater than 2 in. (51 mm) from ends and not greater than 24 in. (610 mm) OC.

**B. Studs** — "C-H", "E" (back-to-back) or "C-T"-shaped studs, min 2-1/2 in. (64 mm) deep, fabricated from min 25 MSG galv steel. Cut to lengths 3/8 to 1/2 in. (10 to 13 mm) less than floor-to-ceiling height and spaced 24 in. (610 mm) OC.

**C. Gypsum Board\*** — 1 in. (25 mm) thick gypsum liner panels and 1/2 in., 5/8 in. or 3/4 in. (13, 16 or 19 mm) thick gypsum panels installed as specified in the individual U400, V400 or W400 Series shaft wall designs in the UL Fire Resistance Directory.

**The hourly ratings of the joint system are equal to the hourly fire rating of the wall.**

**3. Fill, Void or Cavity Material\* - Sealant** — Max separation between top of floor and bottom of gypsum board is 1/2 in. (13 mm). Min 5/8 in. (16 mm) thickness of fill material installed on finish side of the wall between the bottom of the gypsum board and the

top of the concrete floor.

**RECTORSEAL** — FlameSafe, FS 900+ FlameSafe FS 1900, [Metacaulk 1000](#), [Metacaulk MC 150+](#), [Metacaulk 350i](#), Biostop 350i, Biostop BF [150+](#) or Biostop 500+

\*,+ Indicates such products shall bear the UL or cUL Certification Mark for jurisdictions employing the UL or cUL Certification (such as Canada), respectively.

Reprinted from the Online Certifications Directory with permission from UL. ©UL LLC