

F Rating — 2 Hr  
T Rating — 0 Hr

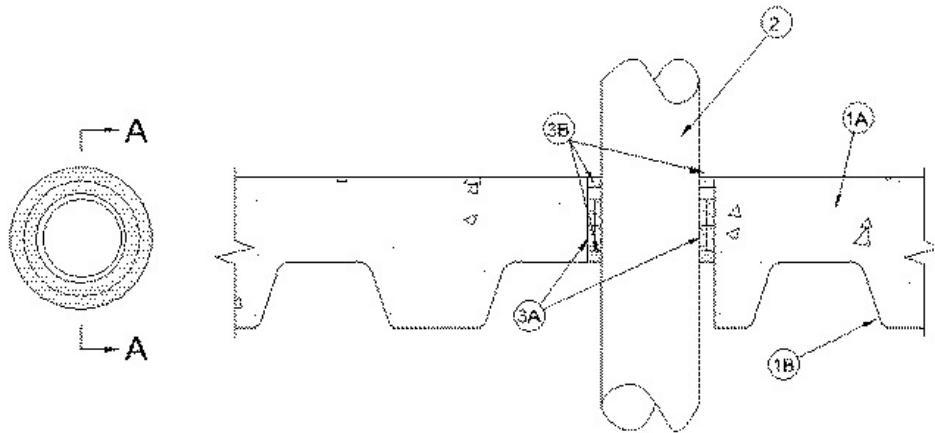

**1. Floor Assembly** — The fire-rated unprotected concrete and steel or concrete floor assembly shall be constructed of the materials and in the manner described in the individual D900 Series Floor-Ceiling Design in the UL Fire Resistance Directory and shall include the following construction features:

**A. Concrete** — Min 3 in. thick reinforced lightweight or normal weight (100-150 pcf) concrete.

**B. Steel Floor and Form Units\*** — Composite or noncomposite max 3 in. deep galv steel fluted units as specified in the individual Floor-Ceiling design. Max diam of opening is 5-1/2 in.

**1A. Floor Assembly** — As an option, floor may be constructed of min 4 in. thick reinforced lightweight or normal weight (100-150 pcf) concrete. Max diam of opening is 5-1/2 in.

**2. Through Penetrants** — One nonmetallic penetrant installed concentrically within the firestop system. The annular space between pipe and periphery of opening shall be 1/2 in. Pipe to be rigidly supported on both sides of the floor assembly. The following types and sizes of nonmetallic pipes may be used:

**A. Polyvinyl Chloride (PVC)** — Pipe Nom 4 in. diam (or smaller) Schedule 40 (or heavier) solid core or cellular core PVC pipe for use in closed (process or supply) or vented (drain, waste or vent) piping systems.

**B. Chlorinated Polyvinyl Chloride (CPVC)** — Pipe Nom 4 in. diam (or smaller) SDR 13.5 CPVC pipe for use in closed (process or supply) piping systems.

**3. Firestop System** — The firestop system shall consist of the following:

**A. Fill, Void or Cavity Materials\* — Wrap Strip** — 3/4 Two layers of nom 1/4 in. thick intumescent elastomeric material faced on one side with a plastic film, supplied in 1 or 2 in. wide strips. Wrap strips individually wrapped around nonmetallic pipe (film side exposed) with ends butted and held in place with tape or tie wire. Butted ends in successive layers shall be offset. Wrap strip recessed 1/2 in. from bottom of surface of steel deck or concrete floor. Two stacks of two layers of wrap strip required when 1 in. wide wrap strips are used or one stack of 2 in. wide wrap strips required when 2 in. wide wrap strips are used.

**RECTORSEAL** — [Metacaulk Wrap Strip](#)

**B. Fill, Void or Cavity Material\* — Caulk** — Min 1/2 in. thickness of sealant applied within the annulus, flush with top and bottom surfaces of steel deck or concrete floor.

**RECTORSEAL** — [Metacaulk 1000](#)

\*,+ Indicates such products shall bear the UL or cUL Certification Mark for jurisdictions employing the UL or cUL Certification (such as Canada), respectively.