

F Rating — 2 Hr
T Rating — 1 Hr

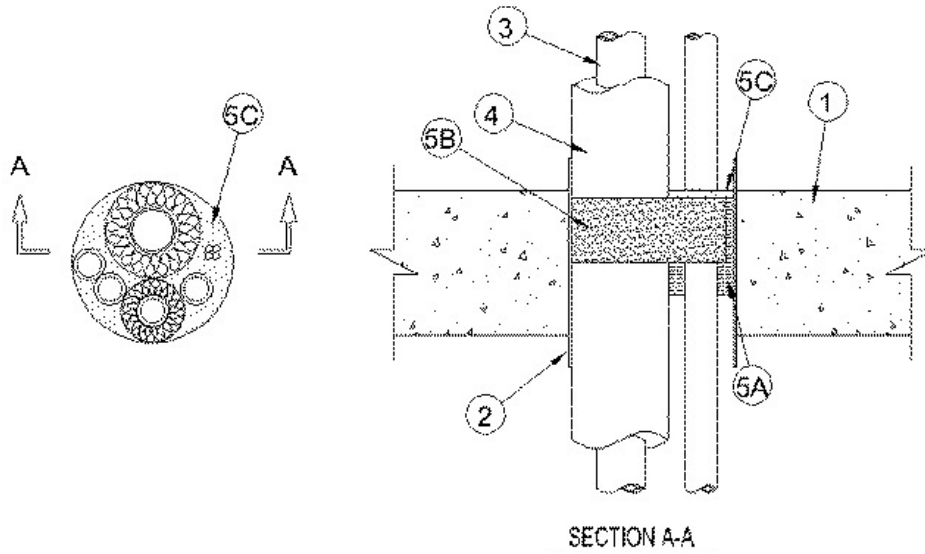

1. **Floor or Wall Assembly** — Min 4-1/2 in. thick reinforced lightweight or normal weight (100-150 pcf) concrete. Wall may also be constructed of any UL Classified **Concrete Blocks***. Max diam of opening 6 in.

See **Concrete Blocks** (CAZT) category in Fire Resistance Directory for names of manufacturers.

2. **Steel Sleeve** — (Optional) - Cylindrical sleeve fabricated from min 0.036 in. thick (No. 20 gauge) galv sheet steel and having a min 1 in. lap along the longitudinal seam. Length of steel sleeve to be 1/2 in. to 2 in. more than the overall thickness of the floor or wall, respectively, such that, when installed in circular opening, the end of the sleeve projects a max 1 in. from top surface of the floor and a max of 1 in. from each surface of wall. Sleeve installed by coiling the sheet steel to a diam smaller than the through opening, inserting the coil through the openings and releasing the coil to let it uncoil against the circular openings in the concrete floor or wall.

3. **Through Penetrants** — A max of four pipes, conduits or tubes and a max of four cable lengths to be installed within the opening. Annular space between the penetrants and the periphery of the opening shall be min 1/4 in. to max 1-1/2 in. Penetrants to be rigidly supported on both sides of floor or wall assembly. The following types and sizes of metallic pipes, conduits or tubing may be used:

A. **Metallic Pipes** — A max of three metallic pipes, conduits or tubing may be used. The following types and sizes may be used:

A1. **Steel Pipe** — Nom 1 in. diam (or smaller) Schedule 5 (or heavier) steel pipe.

A2. **Conduit** — Nom 1 in. diam (or smaller) electrical metallic tubing or rigid steel conduit.

A3. **Copper Tubing** — Nom 1 in. diam (or smaller) Type L (or heavier) copper tubing.

A4. **Copper Pipe** — Nom 1 in. diam (or smaller) Regular (or heavier) copper pipe.

B. **Nonmetallic Pipes** — A max of one nonmetallic pipe or conduit may be used. A min 1/4 in. space must be maintained between uninsulated metallic pipes, conduits or tubing and nonmetallic pipes or conduits. The following types and sizes of nonmetallic pipes or conduits may be used:

B1. **Polyvinyl Chloride (PVC) Pipe** — Nom 1-1/4 in. diam (or smaller) Schedule 40 solid or cellular core PVC pipe for use in closed (process or supply) or vented (drain, waste or vent) piping system.

B2. **Chlorinated Polyvinyl Chloride (CPVC) Pipe** — Nom 1-1/4 in. diam (or smaller) SDR 13.5 CPVC pipe for use in closed (process or supply) piping systems.

B3. **Rigid Nonmetallic Conduit++** — Nom 1-1/4 in. diam (or smaller) Schedule 40 PVC conduit installed in accordance with Article 347 of the National Electrical Code (NFPA No. 70.)

C. **Cables** — A max of four cables may be used. Max 1/C No. 12 AWG power and control cables; XLPE or PVC insulation with XLPE or PVC jacket.

4. **Pipe Covering** — The following types and sizes of pipe coverings may be used with the metallic pipes or tubes:

A. **Tube Insulation - Plastics++** — Nom 3/4 in. thick acrylonitrile butadiene/polyvinyl chloride (AB/PVC) flexible foam furnished in the form of tubing.

See **Plastics** (QMFZ2) category in the Plastics Recognized Component Directory for names of manufacturers. Any Recognized Component tube insulation material meeting the above specifications and having a UL94 Flammability Classification of 94-5VA may be used.

B. **Pipe Covering*** — Nom 1/2 in. thick hollow cylindrical heavy density glass fiber units jacketed on the outside with an all service jacket. Longitudinal joints sealed with metal fasteners or factory-applied self-sealing lap tape. Transverse joints secured with metal fasteners or with butt tape supplied with the product.

See **Pipe and Equipment Covering - Materials** (BRGU) category in the Building Materials Directory for names of manufacturers. Any pipe covering material meeting the above specifications and bearing the UL Classification Marking with a Flame Spread Index of 25 or less and a Smoke Developed Index of 50 or less may be used.

5. **Firestop System** — The firestop system shall consist of the following:

A. **Packing Material** — Min 3 in. thickness of min 4 pcf mineral wool batt insulation firmly packed into opening as a permanent form. Packing material to be recessed from top surface of floor or from both surfaces of wall to accommodate the required thickness of fill material.

B. **Fill, Void or Cavity Materials* - Wrap Strip** — Nom 1/4 in. thick by 2 in. wide intumescent wrap strips. One layer of wrap strip is wrapped tightly encompassing the penetrants with the ends butted and held in place with duct tape. Wrap strip to be recessed from top surface of floor or from both surfaces of wall to accommodate the required thickness of fill material (See item 5C).

RECTORSEAL — [Metacaulk Wrap Strip](#)

C. **Fill, Void or Cavity Materials* - Caulk** — Min 1/2 in. thickness of caulk applied within the annulus, flush with top surface of floor or with both surfaces of wall.

RECTORSEAL — [Metacaulk 1000](#), [Metacaulk 150+](#)

++ Bearing the UL Recognized Component Mark

*,+ Indicates such products shall bear the UL or cUL Certification Mark for jurisdictions employing the UL or cUL Certification (such as Canada), respectively.

Reprinted from the Online Certifications Directory with permission from UL. ©UL LLC