

F Rating — 2 Hr
T Ratings — 0 and 1/2 Hr (see Item 3A)

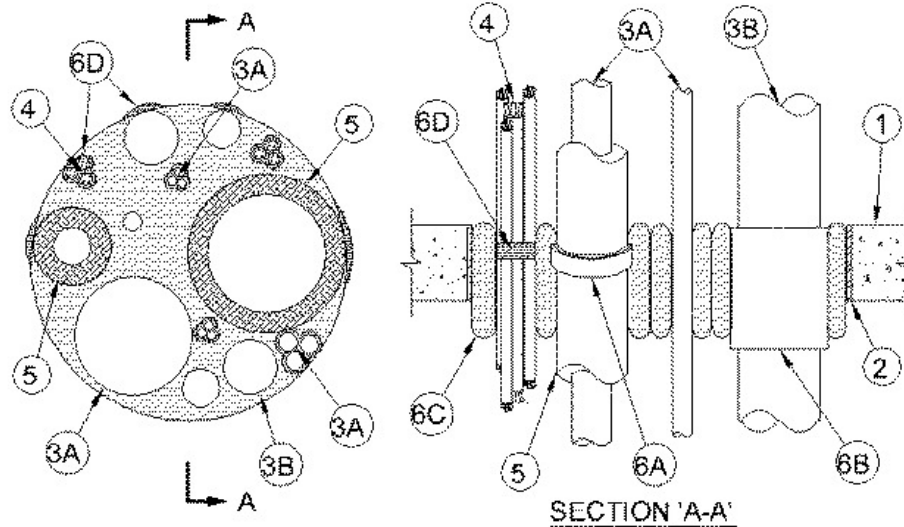

1. **Floor or Wall Assembly** — Min 4-1/2 in. (114 mm) thick reinforced lightweight or normal weight (100-150 pcf or 1600-2400 kg/m³) concrete. Wall may also be constructed of any UL Classified **Concrete Blocks***. Floor may also be constructed of any 6 in. thick UL Classified hollow core **Precast Concrete Units**. Max diam of opening is 31-1/2 in. (800 mm) or max 779 in.2 (5,026 cm²) with max 31-1/2 in. dimension. When precast concrete units are used the max diam of opening is 7 in. (178 mm) or max 49 in.2 (316 cm²) with max 7 in. (178 mm) dimension.

See **Concrete Blocks (CAZT)** and **Precast Concrete Units*** (CFTV) categories in the Fire Resistance Directory for names of manufacturers.

2. **Metallic Sleeve** — (Optional) - Nom 31-1/2 in. (800 mm) diam (or smaller) Schedule 5 (or heavier) steel sleeve cast or grouted into floor or wall assembly, flush with floor or wall surfaces.

3A. **Through Penetrants** — A max of six 1 in. (25 mm) diam, four 2 in. (51 mm) diam (or smaller), two 4 in. (102 mm) diam (or smaller) and two 12 in. (305 mm) diam (or smaller) metallic pipes, conduits or tubing to be installed within the firestop system. The annular space between the pipes, conduits or tubing and the periphery of the opening shall be min 0 in. (point contact) to max 1-1/4 in. (32 mm). Separation between pipes, conduits or tubing shall be min 1 in. (25 mm) to max 2-3/8 in. (60 mm). Pipes of max 2 in. (51 mm) diam may be bundled together in group of three or less. Pipes, conduits or tubing to be rigidly supported on both sides of floor or wall assembly. The following types and sizes of pipes, conduits and tubes may be used:

A. **Steel Pipe** — Nom 12 in. (305 mm) diam (or smaller) Schedule 30 (or heavier) steel pipe.

B. **Iron Pipe** — Nom 12 in. (305 mm) diam (or smaller) cast or ductile iron pipe.

C. **Steel Pipe** — Nom 4 in. (102 mm) diam (or smaller) Schedule 5 (or heavier) steel pipe.

D. **Iron Pipe** — Nom 4 in. (102 mm) diam (or smaller) cast or ductile iron pipe.

E. **Conduit** — Nom 4 in. (102 mm) diam (or smaller) rigid steel conduit or nom 4 in. diam (or smaller) steel electrical metallic tubing (EMT).

F. **Copper Pipe** — Nom 4 in. (102 mm) diam (or smaller) Regular (or heavier) copper pipe.

G. **Copper Tube** — Nom 4 in. (102 mm) diam (or smaller) Type L (or heavier) copper tube.

H. **Copper Pipe** — Nom 2 in. (51 mm) diam Type K copper tube.

I. **Copper Pipe** — Nom 1 in. diam (25 mm) Type K copper tube.

When any un-insulated pipe is used, the T-Rating is 0 hr.

3B. **Through Penetrant** — A max of two nonmetallic pipes or conduits to be installed either concentrically or eccentrically within the firestop system. The annular space between the pipe and the periphery of opening shall be min 1/2 in. (13 mm) to max 1 in. (25 mm). The separation between nonmetallic pipes and other penetrants shall be a min 1 in. (25 mm). Pipe or conduit to be rigidly supported on both sides of floor or wall assembly. The following types and sizes of pipes and conduits may be used:

A. **Polyvinyl Chloride (PVC) Pipe** — Nom 4 in. (102 mm) diam (or smaller) Schedule 40 cellular or solid core PVC pipe for

use in closed (process or supply) or vented (drain, waste or vent) piping systems.

B. Chlorinated Polyvinyl Chloride (CPVC) Pipe — Nom 4 in. (102 mm) diam (or smaller) SDR 13.5 CPVC pipe for use in closed (process or supply) piping systems.

C. Rigid Nonmetallic Conduit+ — Nom 4 in. (102 mm) diam (or smaller) Schedule 40 PVC conduit installed in accordance with the National Electrical Code, (NFPA No. 70).

4. Cables — A max of two nom 3 in. (76 mm) diam (or smaller) tight bundle of cables. Each cable bundle spaced min 1 in. (25 mm) from other cable bundle and penetrants. Annular space between cable bundles and periphery of opening to be min 0 in. (point contact) to max 1 in. (25 mm). Cable bundles to be rigidly supported on both sides of floor or wall assembly. Any combination of the following types and sizes of cables may be used:

A. Max 400 pairs, 24 AWG telephone communication cable with PVC insulation and jacket.

B. Max 62.5/125 fiber optic cable with PVC insulation and jacketing.

C. Max 7/C No. 12 AWG copper conductor power and control cables; XLPE or PVC insulation with XLPE or PVC jacket.

D. Max RG59/U (or smaller) coaxial cable with fluorinated ethylene insulation and jacketing.

E. Type RG 59/U coaxial cable with polyethylene (PE) insulation and PVC jacket.

F. 4/C No. 14 AWG (or smaller) copper conductor PVC jacketed aluminum clad or steel clad TEK cable with XLPE insulation.

5. Pipe Insulation — (Optional) - The following types of pipe insulations may be installed on one or more of the metallic pipes (Item 3A):

A. Pipe and Equipment Covering Materials* — Max 2 in. (51 mm) thick hollow cylindrical heavy density (min 3.5 pcf or 56 kg/m³) glass fiber units jacketed on the outside with an all service jacket. Longitudinal joints sealed with metal fasteners or factory-applied self-sealing lap tape. Transverse joints secured with metal fasteners or with butt tape supplied with the product.

See **Pipe and Equipment Covering Materials** (BRGU) category in the Building Materials Directory for names of manufacturers. Any pipe covering meeting the above specifications and bearing the UL Classification Marking with a Flame Spread Index of 25 or less and a Smoke Developed Index of 50 or less may be used.

B. Pipe Covering Materials* — Max 2 in. (51 mm) thick unfaced mineral fiber pipe insulation having a nom density of 7 pcf (112 kg/m³), or heavier, and sized to the outside diam of the pipe or tube. Pipe insulation secured with min 18 AWG steel wire spaced max 12 in. (305 mm) OC.

INDUSTRIAL INSULATION GROUP L L C — High Temperature Pipe Insulation 1200, High Temperature Pipe Insulation BWT and High Temperature Pipe Insulation Thermaloc

C. Sheathing Material* — Use in conjunction with Item 5B. Foil-scrim-kraft or all service jacket material shall be wrapped around the outer circumference of the pipe insulation (Item 5B) with the kraft side exposed. Longitudinal and transverse joints sealed with metal fasteners or butt tape.

See **Sheathing Materials** (BVDV) category in the Building Materials Directory for names of manufacturers. Any sheathing material meeting the above specifications and bearing the UL Classification Marking with a Flame Spread Index of 25 or less and a Smoke Developed Index of 50 or less may be used.

6. Firestop System — The firestop system shall consist of the following:

A. Fill, Void or Cavity Material* — Wrap Strip — Nom 1/4 in. (6 mm) thick intumescent material faced on both sides with a plastic film, supplied in 1-1/2 in. (38 mm) wide strips. Two layers of wrap strip installed around outer circumference of each insulated metallic pipe with ends butted and held in place with masking tape. The wrap strip shall be recessed a nom 1 in. (25 mm) from the top surface of the concrete floor. In walls, the wrap strip shall be installed from both surfaces of the wall such that the exposed edges of the wrap strip are recessed a nom 1 in. from each side of the wall.

RECTORSEAL — FlameSafe® Wrap Strip, [Metacaulk Wrap Strip](#) or Biostop Wrap Strip

B. Firestop Device — Galv steel sleeve lined with an intumescent material sized to fit the specific diam of the through penetrant. Device to be wrapped around outer circumference of each nonmetallic pipe or conduit (Item 3B) and installed through the annular space of the opening. The device may be secured together by means of min 1/2 in. (13 mm) wide by 0.028 in. (0.71 mm) thick stainless steel hose clamps or min 1/8 in. (3.2 mm) diam by 1/2 in. (13 mm) long steel pop rivets spaced max 4 in. (102 mm) OC. As an option, the device may be secured to the penetrant with 3/4 in. (19 mm) wide by 0.007 in. (0.18 mm) thick glass cloth electrical tape continuously wrapped twice around the outer circumference of through

penetrant, spaced a max 2 in. (51 mm) OC. In floors 8 in. (203 mm) or less, the top edge of the device may be installed flush with the top surface and extend a max 3-1/2 in. (89 mm) below the bottom surface of the floor or the bottom edge of the device may be installed flush with the bottom surface of the floor. In floors greater than 8 in. (203 mm), the bottom edge of the device may be installed flush with the bottom surface of the floor or extend a max 3-1/2 in. (89 mm) below the bottom surface of the floor. In walls having a nominal thickness of 8 in. (203 mm) or less, the device shall be centered within the wall and extend equally beyond each surface of the wall. In walls having a nominal thickness greater than 8 in. (203 mm), two devices shall be installed within the opening with butted ends and extend equally beyond each surface of the wall.

RECTORSEAL — FlameSafe® Intumescent Sleeve, [Metacaulk Intumescent Sleeve](#) or Biostop Intumescent Sleeve

B1. Fill, Void or Cavity Material* — Wrap Strip — (Not Shown). When max 2 in. (51 mm) diam nonmetallic pipes (Item 3B) are used, wrap strip may be used as an option to the firestop device (Item 6B).

Nom 1/4 in. (6 mm) thick intumescent material faced on both sides with a plastic film, supplied in 1-1/2 in. (38 mm) wide strips. One layer of wrap strip installed around outer circumference of each nonmetallic pipe with ends butted and held in place with masking tape. The wrap strip shall be recessed a nom 1 in. (25 mm) from the top surface of the concrete floor. In walls, the wrap strip shall be installed from both surfaces of the wall such that the exposed edges of the wrap strip are recessed a nom 1 in. (25 mm) from each side of the wall. If floor is constructed of hollow-core precast concrete units, wrap strip to be installed from top and bottom floor surfaces and recessed a nom 1 in. from each surface.

RECTORSEAL — FlameSafe® Wrap Strip, [Metacaulk Wrap Strip](#) or Biostop Wrap Strip

C. Fill, Void or Cavity Materials — Pillow-like material of size Nos. 1, 2 and 4 shall be tightly packed with no visible air space into opening to fill annular space between metallic penetrants, nonmetallic penetrants, cable bundles and periphery of opening. Pillows installed vertically with long edges parallel to floor or wall thickness and top of pillows shall be flush with floor surface. In walls, pillows shall be centred within wall thickness.

RECTORSEAL — FlameSafe® Pillows, [Metacaulk Pillows](#) or Biostop Pillows

D. Fill, Void or Cavity Materials* — Putty — Min 1 in. (25 mm) thickness of kneaded putty material packed tightly around cable bundles (Item 4), in all interstices between cables, around group of penetrants of max 2 in. diam (Item 3A) and within all void areas between pillows. Min 1 in. (25 mm) thickness of putty to be applied at all points of contact between penetrants and periphery of opening. Putty installed from top surface of floor or from both surfaces of wall. If floor is constructed of hollow-core precast concrete units, putty to be installed from top and bottom floor surfaces. Putty around cable bundles and group of penetrants shall be recessed 1 in. (25 mm) from floor or wall surfaces and installed prior to the installation of pillows (Item 6C).

RECTORSEAL — Type FSP1000, [Metacaulk Fire Rated Putty](#), Biostop Fire Rated Putty

*,+ Indicates such products shall bear the UL or cUL Certification Mark for jurisdictions employing the UL or cUL Certification (such as Canada), respectively.