

F Ratings — 2 and 4 Hr (See Item 5)
T Ratings — 0 and 2 Hr (See Items 3 and 5)

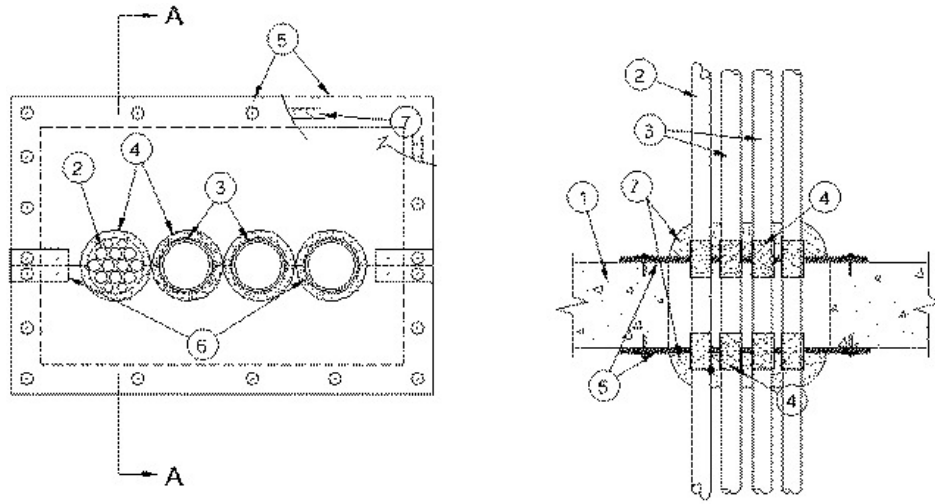

SECTION A-A

1. **Floor or Wall Assembly** — Min 4-1/2 in. (114 mm) thick lightweight or normal weight (100-150 pcf or 1600-2400 kg/m³) concrete. Wall may also be constructed of any UL Classified **Concrete Blocks***. Max area of opening 900 sq in. (5806 cm²) with max dimension 30 in. (762 mm).

See **Concrete Blocks** (CAZT) category in the Fire Resistance Directory for names of manufacturers.

2. **Cables** — Aggregate cross-sectional area of cables in bundle not to exceed nom 12-1/2 sq in. or 81 cm² (4 in. or 102 mm diam bundle). The space between cables and periphery of opening shall be min 1 in. (25 mm). Any combination of the following types and sizes of cables may be used:

- A. Max 750 kcmil power cables; THHN or THWN jacketed
- B. Max 8C, No.12 AWG multiconductor power and control cables; jacketed.
- C. Max 300 pair No. 24 AWG copper conductor communication cable with polyvinyl chloride insulation and jacket material.
- D. Multiple fiber optical communication cable jacketed with polyvinyl chloride.
- E. Max 25 pr/24 AWG telephone cable with polyethylene insulation and polyvinyl chloride jacket.

3. **Through-Penetrants** — A max of three pipes or conduits installed within the opening. Pipes or conduits installed along the same center line (as Item 2 if used) so that only one seam will exist in the composite sheet. The space between pipes or conduits, pipes or conduit and cables, and between pipes or conduits and periphery of opening shall be min 1 in. The following types and sizes of metallic pipes or conduits may be used:

- A. **Steel Pipe** Nom 6 in. (152 mm) diam (or smaller) Schedule 10 (or heavier) steel pipe.
- B. **Iron Pipe** Nom 6 in. (152 mm) diam (or smaller) cast or ductile iron pipe.
- C. **Conduit** Nom 6 in. (152 mm) diam (or smaller) steel electrical metallic tubing.
- D. **Conduit** Nom 6 in. (152 mm) diam (or smaller) rigid steel conduit.

When any of the above metallic penetrants are used, T Rating is 0 hr.

4. **Fill, Void or Cavity Materials*** — **Putty** — Nom 2 in. (51 mm) wide by 1/8 in. (3 mm) thick putty strips installed to tightly follow the contour of the through-penetrants around the entire perimeter. Adjoining lengths of putty strips butt seamed together by hand. One layer of putty required on each side of floor or wall assembly installed to project approx 1 in. (25 mm) beyond each face of the composite sheet (Item 5) on both sides of floor or wall assembly.

RECTORSEAL — [Metacaulk Fire Rated Putty](#)

5. **Fill, Void or Cavity Materials*** — **Composite Sheet** — Rigid aluminum foil-faced intumescent sheet with steel backer. Sheets

cut to tightly follow the contour of the cable bundle and/or through-penetrants. Sheets cut to lap a min of 2 in. (51 mm) onto floor or wall surfaces. When sheet installed on both sides of the floor or wall assembly, F Rating is 4 hr. As an option for penetrants through floors, the sheet may be installed on only the top surface of the floor to attain a 2 hr F Rating and a 0 hr T Rating. When sheet is installed on only the top surface of the floor, the putty (Items 4 and 7) fill material is also required to be installed on only the top surface of the floor. Sheet to be installed with the steel backer exposed (aluminum foil facing against floor or wall surface) and secured to floor or wall surface with min 3/16 in. (4.8 mm) diam by 1-1/4 in. (32 mm) long steel anchor screws, in conjunction with min 1-1/4 in. (32 mm) diam steel fender washers. Max spacing of fasteners not to exceed 6 in. (152 mm) and max 2 in. (51 mm) from ends, with additional fasteners located on each side of butted seams or slits (see Item 6) made to permit installation or the sheet around the cable tray.

RECTORSEAL — [Metacaulk Composite Sheet](#)

6. Cover Strip — Min 2 in. wide strip of min 0.019 in. thick (26 ga) stainless steel centered over entire length of the butted seam or slit made in the composite sheet (Item 5). Prior to installation of the steel strip, the seam or slit in the composite sheet shall be covered with a nom 1/2 by 1/8 in. (13 by 3 mm) thick strip of putty, 1/2 in. (13 mm) wide by 1/16 in. (1.6 mm) thick joint strip or 1/2 in. (13 mm) bead of sealant (Item 7). Steel cover strip secured to steel backer of composite sheet with steel sheet metal screws or steel rivets spaced max 3 in. OC on each side of seam or slit.

7. Fill, Void or Cavity Materials* — One layer of 1/2 by 1/8 in. (13 by 3 mm) thick putty strips or 1/2 in. (13 mm) wide by 1/16 in. (1.6 mm) thick joint strip or 1/2 in. (13 mm) diam bead of caulk positioned under composite sheet around entire perimeter of through opening and under steel cover strip. Generous application of putty (1 in. (25 mm) wide by 2 in. (51 mm) high dome) to be applied around the penetrating items at their egress from the intumescent sheet on both sides of the floor or wall assembly. When annular space between cable bundle and penetrant or between penetrants in less than 2 in. (51 mm) space between cable bundle and penetrant or between penetrants shall be filled to a min. height of 2 in. (51 mm) above floor or wall.

RECTORSEAL — [Metacaulk Fire Rated Putty](#)

RECTORSEAL — [Metacaulk Joint Strip](#)

RECTORSEAL — [Metacaulk 1000](#)

*,+ Indicates such products shall bear the UL or cUL Certification Mark for jurisdictions employing the UL or cUL Certification (such as Canada), respectively.

Reprinted from the Online Certifications Directory with permission from UL. ©UL LLC